

1697 Cole Boulevard, Suite 200
Golden, Colorado 80401
Tel: (303) 239-5400
Fax: (303) 239-5454

Prepared for: Cherry Creek Basin Water Quality Authority

Project Title: Cherry Creek at Shop Creek Trail

Project No: 137994

Memorandum

Subject: Final Recommended Stream Reclamation Plan

Date: December 3, 2010

To: William Ruzzo, P.E.

From: Sarah Reeves

Tom Rossillon, P.E.

Jennifer Winters, P.E.

Chris Reichard

Prepared by: Jennifer Winters, P.E., Chris Reichard

Reviewed by: Thomas M. Rossillon, P.E., Sarah Reeves

Limitations:

This document was prepared solely for the Cherry Creek Basin Water Quality Authority in accordance with professional standards at the time the services were performed and in accordance with the contract between Cherry Creek Basin Water Quality Authority and Brown and Caldwell dated 7/8/2009. This document is governed by the specific scope of work authorized by the Cherry Creek Basin Water Quality Authority; it is not intended to be relied upon by any other party except for regulatory authorities contemplated by the scope of work. We have relied on information or instructions provided by the Cherry Creek Basin Water Quality Authority and other parties and, unless otherwise expressly indicated, have made no independent investigation as to the validity, completeness, or accuracy of such information.

TABLE OF CONTENTS

TABLE OF CONTENTS 2

1. INTRODUCTION..... 4

2. PROJECT ALTERNATIVES 4

 2.1 Option 1 4

 2.2 Option 2 4

 2.3 Option 3 5

3. ISSUES AND CONCERNS..... 5

 3.1 Channel Slope 5

 3.2 Geotechnical Evaluation 5

 3.3 Permitting and Endangered Species 6

 3.3.1 Option 1 6

 3.3.2 Options 2 and 3 6

 3.3.3 Preble’s Meadow Jumping Mouse 7

 3.3.4 Permits and Project Scheduling 8

 3.4 Pedestrian Bridges 8

 3.5 Construction Access 8

 3.6 Construction Footprint 8

 3.7 Existing Development 9

 3.8 Bank Stabilization 9

 3.9 Construction Phase Considerations..... 9

4. ALTERNATIVE PROS AND CONS 9

 4.1 Option 1 9

 4.1.1 Pros 10

 4.1.2 Cons 10

 4.2 Option 2 10

 4.2.1 Pros 10

 4.2.2 Cons 10

 4.3 Option 3 10

 4.3.1 Pros 10

 4.3.2 Cons 11

 4.4 Alternative Comparison 11

5. ALTERNATIVE SELECTION 12

6. HYDRAULIC ANALYSIS 12

 6.1 Survey and Cross-Section Information 13

 6.2 Proposed Riffle Drops..... 13

6.3 Design Flow 13

6.4 Boundary Conditions 13

6.5 Manning’s Roughness Coefficients..... 13

6.6 Final Hydraulic Results 13

7. DESIGN DETAILS 14

 7.1 Construction Impacts 14

 7.2 Construction Access 15

 7.3 Construction Cost Opinion 15

8. SUMMARY 17

9. RECOMMENDATIONS 17

10. STREAM STABILIZATION PLAN SET

11. MEMORANDUM FIGURES

 Figure 1 – Plan View, Option 1

 Figure 2 – Plan View, Option 2

 Figure 3 – Plan View, Option 3

 Figure 4 – Existing Stream Channel Profile

12. MEMORANDUM ATTACHMENTS

 Attachment A – Phosphorus Sampling Results

 Attachment B - Cross Sections of Existing Stream Channel

 Attachment C – Geotechnical Analysis Report

 Attachment D – HEC-RAS Model Input for Selected Alternative

 Attachment E – HEC-RAS Model Output for Selected Alternative

 Attachment F – Earthwork Volume Calculation

 Attachment G – Drop Structure Alternatives Considered

1. INTRODUCTION

This memorandum is a summary of the Cherry Creek at Shop Creek Trail Stream Reclamation Plan (SRP). The plan presents a proposed project located along Cherry Creek within Cherry Creek State Park. The proposed project reach is approximately 1,800 linear feet and is bound on the downstream end by the Wetlands Trail pedestrian bridge and on the upstream end by the Shop Creek Trail pedestrian bridge. The purpose of the proposed project is to improve water quality within Cherry Creek Reservoir by reducing phosphorus loading from existing stream bank erosion within the project reach. Attachment A includes the results of phosphorus sampling from the banks of the channel along the project reach, which demonstrates that the soil contains approximately 1.1 pounds of phosphorus per ton, and is consistent with other Authority PRFs.

This memorandum presents three project alternatives that have been evaluated for the stream reclamation plan, and presents issues and concerns identified during the alternatives analysis and a list of pros and cons for each alternative. It also presents information regarding the process for deciding which option was ultimately selected for further development, including preliminary design drawings.

2. PROJECT ALTERNATIVES

Three project alternatives were analyzed for the stream reclamation plan. Because a majority of the erosion is occurring within the upstream 600 feet of the project reach, all three project alternatives are concentrated within this upstream reach. It should be noted that each of the three options includes a one-foot deep stilling pool at the downstream end of the existing Aurora Water stream stabilization project.

2.1 Option 1

Option 1 consists of building a sequence of five riffle drop structures along the upstream reach of the project. Figure 1 presents the configuration of the option within the project site. Each of the five riffle drops will provide approximately one foot of drop for a combined drop of approximately five feet. Preliminary drop spacing used for this analysis was approximately 100 feet, with the extent of riprap channel lining extending 50 feet downstream from the riprap crest. Because of the drop spacing, most of the 600 feet of channel in the project reach will be disturbed during construction.

A potential modified option within this Option is to provide three approximately 1.75-foot riffle drops within the reach. If the configuration of five one-foot riffle drops within the upper 600 feet of the project reach is considered to have a significant, undesirable impact on the “natural” state of the channel due to the extent of riprap in the channel and overbank areas, this may be an alternative worth analyzing in greater detail at the time of final design. The footprint of individual riffle drop structures increases as the drop through the structure increases but, by increasing the drop in each structure, there will be fewer structures required and the impact on the overall project reach may be reduced if this alternative is selected.

2.2 Option 2

Option 2 consists of building one riffle drop structure downstream of one grouted boulder drop structure. Figure 2 presents the configuration of the option within the project site. The proposed riffle drop structure would provide one foot of drop, while the grouted boulder drop structure would provide four feet of drop.

2.3 Option 3

Option 3 consists of building one grouted boulder drop structure downstream of a riffle drop structure. Figure 3 presents the configuration of the option within the project site. The proposed riffle drop structure would provide one foot of drop, while the grouted boulder drop structure would provide four feet of drop.

3. ISSUES AND CONCERNS

3.1 Channel Slope

The URS Corporation prepared a Master Plan for the Cherry Creek watershed upstream of Cherry Creek State Park. Per the master plan, the stable channel slope for Cherry Creek is 0.0022 ft/ft for the channel reaches upstream of the Park. The project reach is approximately 1,800 feet long, from the Wetlands Trail Bridge at the downstream end to the Shop Creek Bridge at the upstream end. The downstream portion of the project reach, starting approximately 700 feet downstream from the Shop Creek Bridge and extending 1,100 feet to the Wetlands Trail Bridge, has an existing slope of approximately 0.0022 ft/ft, as shown on the existing channel profile shown on Figure 4. Therefore, major channel stabilization efforts in this area do not appear to be necessary. This was verified by observations of stream channel conditions during a field visit and hydraulic analysis of the channel.

During the field visit it was apparent that incising of the channel is much less pronounced in the downstream portion of the project reach, although the channel continues to degrade. See Attachment B for cross section plots of the existing channel. In the upper section of the project reach, the existing channel slopes range from approximately 0.007 ft/ft to 0.033 ft/ft, which are much greater than the recommended channel slope of 0.0022 ft/ft. To maintain stable channel slopes in the project reach, approximately five feet of controlled drop through some type of structure or structures is required. It is recommended that the proposed channel stabilization structures be concentrated along the upstream reach of the project where the majority of the erosion is occurring and where the channel slopes are currently unstable.

In addition, two locations have been identified where installation of control structures would stabilize the channel against further degradation. One is on the main channel near the lower end of the project area, at the Wetlands Trail foot bridge, and the other is on a tributary channel just above the confluence with the main channel, immediately downstream from the steep, upper section of the creek.

3.2 Geotechnical Evaluation

Brown and Caldwell subcontracted with JA Cesare and Associates, Inc. (JAC), to perform a geotechnical evaluation at the site. A copy of the report is included as Attachment C to this report. JAC found that the subsoil consists of loamy soil with sands, clayey sand, and sandy clay lenses. Due to accessibility issues, only a single bore hole was drilled, near the Shop Creek Trail Bridge, at the upper end of the reach. As there has been disturbance in the vicinity of the bore hole, conditions in the upper layer of soil may not be representative of subsoil conditions in relatively undisturbed areas lower in the reach.

The results of the geotechnical investigation revealed that the majority of subgrade soils were clean, flowable sands, overlain by a layer of gravel and sand and gravel with cobbles up to approximately six inches in diameter in the top three to five feet of soil. Bedrock was not encountered in a borehole depth of 51 feet below ground surface. The flowable sands and groundwater conditions indicate that deep, open excavations will be difficult to maintain. Shoring and dewatering will likely be necessary during construction to maintain stable working conditions in the subgrade beneath structures. Stabilization rock may also be required if soft conditions persist.

3.3 Permitting and Endangered Species

All three of the options would require a Clean Water Act Section 404 permit from the U.S. Army Corps of Engineers (USACE). Each option would also require addressing the Preble's meadow jumping mouse (*Zapus hudsonius preblei*) during the permit review process. However, given that all three options would benefit the stream channel and local riparian and wetland conditions, we expect that the project would be viewed favorably by the USACE and the U.S. Fish and Wildlife Service (USFWS) regarding the Preble's mouse. Generic discussions about this type of project with the USFWS indicated that the USFWS generally likes these types of projects because of their riparian benefits. The following subsections address the possible permits that may be required for each option.

Construction of the control structures on the main channel and on a tributary channel downstream from the disturbed section of the main channel are likely to be concrete sills across the stream channels. The active stream degradation observed in the channel over the past several months make these critical to the long-term success of the project, as they are designed to provide a check against active headcutting of the channel bed and banks. While concrete construction in the stream channel is generally not looked upon favorably by the federal agencies, the configuration and function of these structures to provide protection of stream water quality should preclude major issues with permitting, particularly if they do not include significant drops.

In addition to these federal permits, construction of the proposed drop structures for any of the three Options may require both state and local permits for stormwater management and sediment control due to the size and level of disturbance. The Colorado Department of Public Health and Environment (CDPHE) Water Quality Division will require that the project have a Stormwater Management Plan (SWMP) in place, and Arapahoe County will require preparation of a Grading and Erosion & Sediment Control (GESC) plan for control of sediment during and after construction.

3.3.1 Option 1

As a stand-alone project, the stream drops under Option 1 could possibly be covered by Nationwide Permit (NWP) 27 if several conditions were met. The USACE has a local policy regarding the use of NWP 27, which limits the height of vertical drops to one foot to allow for the movement of aquatic life and prohibits the use of concrete or grout. Since Option 1 would have drops at one foot each and would not include the use of concrete grout, the use of one-foot riffle drops could be allowed under NWP 27.

However, since the overall project also includes control structures which will be constructed using concrete, it is unlikely that the project can be approved under NWP 27, and an Individual Permit (IP) will be required.

Even without the concrete control structures, the relatively large disturbance footprint of constructing five riffle drops in a 600-foot linear section might cause the USACE to view this as exceeding the "minor impact" threshold that applies to all NWPs. Therefore, regardless of the other factors, the USACE may be likely to invoke their discretion and require an IP due to the large disturbance footprint of the riffle drops in such a short distance.

In addition, since the project will include concrete control structures, it is unlikely that the project can be approved under NWP 27, and an Individual Permit (IP) will be required.

3.3.2 Options 2 and 3

From a USACE permitting standpoint, Options 2 and 3 are essentially the same. In general the USACE and USFWS are less interested in large grouted boulder drops because they can impede the movement of aquatic life and they will not re-vegetate as well as the void-filled riffle drop would. Since either of these options would include a grouted boulder drop of greater than one-foot, and include the use of concrete grout, NWP

27 could not be used for these options. Options 2 or 3 would, therefore, require an IP, which would likely take 6-12 months to obtain.

3.3.3 Preble's Meadow Jumping Mouse

The Preble's mouse is a permitting issue for all three options. Though Preble's have not been captured at or near the project site, the USFWS has indicated that these results are several years old and they would be reluctant to let the Cherry Creek Basin Water Quality Authority (Authority) rely on these results to avoid the mouse issue during permitting. The USFWS rationale is that, since Preble's have been captured on Cherry Creek near its crossing with E-470, they could have migrated downstream to occupy riparian habitat closer to, or at, this project site. Since the project would likely benefit Preble's, and the channel at the upstream end of the project area is quite degraded, it would be worthwhile to have more detailed project discussions with the USFWS about Preble's to determine whether the issue could be avoided. However, for planning purposes at this project stage, we consider this to be an issue that needs to be addressed during permitting.

During our initial site visit in the fall of 2009, we observed riparian conditions in the project area that could support Preble's (dense grasses, wetlands, riparian willow shrub). Given the site conditions and our generic discussions with the USFWS, there are two approaches the Authority could take to address the Preble's issue during the permitting process, as developed below.

3.3.3.1 Approach 1 – Perform a Trapping Survey of the Project Area

As has been done many times along the Front Range, the Authority could commission a trapping survey of the project area to determine if Preble's actually occupy the project area. The issue would be resolved if none are found. However, since Preble's are known to be on Cherry Creek at E-470, the USFWS would likely require negative trapping results over two seasons before agreeing that the project area is not occupied by Preble's. If Preble's are found, this project would require formal Endangered Species Act (ESA) consultation during the USACE permitting process. Given that the project, in the long run, would benefit Preble's despite temporary adverse construction impacts, we feel that the USFWS would generally support the project. The formal consultation process would take about 4-6 months of time, which could be structured to occur concurrently with the USACE IP process, thereby adding time to the approval process timeline. The consultation process would likely be the key schedule driver on the USACE review of NWP 27 under Option 1, should NWP 27 be feasible.

3.3.3.2 Approach 2 – Assume Presence Based on Suitable Habitat

A more common approach is to assume that Preble's are present based on the presence of suitable habitat conditions and skip the trapping survey. This would still require the formal ESA consultation during the USACE permitting, but would skip the cost, time, and uncertainty associated with the trapping survey. Since this project should be viewed favorably by the USACE and USFWS, and the project would benefit riparian and wetland conditions, the potential Preble's mitigation burden is likely to be low.

3.3.3.3 Preble's Approach Recommendation

If the Authority could afford to wait up to two trapping seasons and needed an official presence/absence determination for Preble's, or the potential Preble's mitigation burden was likely to be substantial, then proceeding under Approach 1 would make sense. However, since none of these requirements appear applicable to this project, it is recommended that the Authority proceed under Approach 2 for any of the three project Options.

3.3.4 Permits and Project Scheduling

BC forwarded a copy of the preliminary design drawings for this project, and discussed the issue of the 404 permit with the local office of the Corps of Engineers (USACE) on July 15, 2010. Their feedback was that they felt the proposed drop structure construction on its own could be approved under Nationwide Permit (NWP) 27. However, since the project will also include two concrete control structures to provide additional channel stability downstream from the upper reach, the overall project will likely require an IP to proceed.

Going forward, the project should be submitted formally for review early in the final design process (or even before it starts) so that relevant comments or mitigation requirements that may be attached to the issuance of the 404 permit for the project can be incorporated into the final design package. On the assumption that the Authority would chose to assume that the Preble's mouse is present in the project area rather than perform a trapping survey, the schedule should allow for a 3-5 month review process with the U.S. Fish and Wildlife Service before the USACE can issue their approval.

3.4 Pedestrian Bridges

As the pedestrian bridge at Shop Creek trail (the upstream limit of the project) is not part of the channel reclamation project, it is not included in this memorandum. The downstream pedestrian bridge at Wetlands Trail should be utilized as a "hard-point" for the stream reclamation project. That can be done by incorporating a grade control structure into the new pedestrian bridge. All three alternatives presented in Section 1 assume incorporating the downstream pedestrian bridge as part of a grade control structure.

It is envisioned that the downstream control structure will be a grade sill, with no drop associated with it, tied into the bridge abutments. It is possible that the channel has continued to degrade, which may result in a drop at this structure. The elevation and configuration of the grade sill, bridge abutments, and underside structural elements of the foot bridge will need to be analyzed to ensure adequate capacity through the opening to convey and control the design flow. Typically, grade sills are buried concrete walls 8-12 inches thick that extend across the channel invert and up the banks. It may be desirable from an aesthetic or permitting standpoint to replace the concrete sill with a timber sill, using species such as ironwood or another durable wood, with deep anchors into the ground to hold the timber sill in place during large flow events.

3.5 Construction Access

The only two points to access Cherry Creek along the project reach are at the upstream and downstream pedestrian bridge crossings. Due to the recent construction activity surrounding the Shop Creek Trail foot bridge crossing, construction access to the upstream bridge location is viable. Access at the downstream bridge is possible, but more constrained. Access in the middle reaches of the project will be more difficult due to thick tree and brush cover.

All the options for channel drops presented require access to at least the upper half of the reach and to the lower end at the Wetlands Trail Bridge in order to construct grade control structures. Routing of access to all points of the stream where construction is needed to stabilize the channel should be planned to avoid the near-stream riparian area to the extent possible, while maintaining much of the thick vegetation that has grown in the immediate area and also preserving some trees near the edge of the new channel.

3.6 Construction Footprint

The potential drop structures discussed in Section 3 are a riffle drop and a grouted boulder drop. The construction footprint for the riffle drop is by far the largest. A riffle drop typically has a tie-in bank slope of approximately 10:1. That slope has been increased to 4:1 for this project due to the deep, incised existing

channel. The footprint for the grouted boulder drop structure also has over bank tie-in slopes of 4:1, but since one grouted boulder drop structure takes the place of four riffle drops in the alternatives studied, the overall footprint is reduced for the boulder drop options. The total disturbed area for the project is approximately 5.2 acres, much of it for construction access and staging, which is approximately the same, regardless of the option selected.

3.7 Existing Development

Development in the immediate area of the proposed stream improvements includes the two bridges and trails, and the relatively new grade control structure that is protecting the two City of Aurora water lines that cross Cherry Creek near the upper end of the reach.

The stream at the upper bridge has been stabilized by the construction of the grade control built for protection of the Aurora water lines, and no new improvements are recommended for this area. In addition, the grade control structure itself is not to be disturbed as part of this project. They appear to be functioning as intended and, while not necessarily designed as a permanent solution, the addition of downstream drop structures to stabilize the stream below the existing grade control structure should allow it to continue to function as intended for an extended period.

3.8 Bank Stabilization

The banks along the reach have been impacted by headcutting in many locations. The majority of headcut damage has been confined to the upper section of the reach where the proposed drop structures are to be constructed. However, the downstream reach is also exhibiting minor erosion, which appears to have worsened during preparation of the SRP. A portion of this erosion will be improved by the proposed upstream projects, Consideration was given to repairing/restoring/stabilizing damaged stream banks to provide protection to bared slopes and scarps and allow vegetation an opportunity to permanently stabilize these areas. In some cases, excavation for channel shaping and placement of riprap would have been required to adequately stabilize the stream long term. However, because there is a lack of suitable access and the extent of disturbance during construction would be significant, it was decided not to stabilize the banks as the project would further stabilize the bed profile.

3.9 Construction Phase Considerations

During the construction phase of the project, rerouting of the stream flows will be necessary to allow for construction. Diversion of the stream upstream from the construction area and into a pipeline routed around the construction area will be required, further increasing the overall footprint of the project.

In addition, due to the probable use of the existing Shop Creek Trail alignment as a construction access route, the trail will be likely need to be closed during construction, and a bypass trail may need to be planned and constructed. The Wetlands Trail will be similarly impacted by construction at the lower end of the reach.

4. ALTERNATIVE PROS AND CONS

The following sections provide pros and cons for each of the options considered.

4.1 Option 1

Option 1 consists of building five riffle drop structures along the upstream reach of the project. Figure 1 presents the configuration of the option within the project site.

4.1.1 Pros

- Provides more natural aesthetics with five small drops rather than a grouted boulder drop.
- Has greatest likelihood of being authorized by USACE NWP 27 assuming concrete use is avoided, which would reduce the permitting timeline by several months.

4.1.2 Cons

- Includes more structures to build than other options.
- Spreads stream impact over a longer reach.
- Increases the area of disturbance to land adjacent to the stream.

4.2 Option 2

Option 2 consists of building one riffle drop structure followed by one grouted boulder drop structure. Figure 2 presents the configuration of the option within the project site.

4.2.1 Pros

- Provides a water feature for park users crossing the Shop Creek Trail pedestrian bridge as a result of the grouted boulder drop.
- Requires only two structures to construct.
- Maximizes length of stream at the more “natural” 0.22 percent grade.

4.2.2 Cons

- Increases difficulty of construction with grouted boulder drop structure, given the soil types (per geotechnical report).
- Triggers the need for an IP because of grouted boulder feature.

4.3 Option 3

Option 3 consists of building one grouted boulder drop structure followed by one riffle drop structure. Figure 3 presents the configuration of the option within the project site.

4.3.1 Pros

- Requires only two structures to construct.
- Allows easier access for concrete trucks to an upstream grouted boulder drop.
- Maximizes length of stream at the more “natural” 0.22 percent grade.
- Provides stabilization of flow downstream from larger drop, allowing it to damp out any transient flow characteristics.

4.3.2 Cons

- Increases difficulty of construction of the grouted boulder drop structure, given the soil types (per geotechnical report).
- Triggers the need for an IP because of the grouted boulder feature.

4.4 Alternative Comparison

The following table presents a snapshot comparison of the three options with regard to the intensity of impacts and issues related to each Option.

Table 4-1 Comparison of Options

	Public Visibility	Stream Impact	Construction Impact	404 Permitting Issues	Relative Cost
Option 1 - Five 1-ft Riffle Drops	Minor	Highest	Moderate Impact	NWP Possible*	Lowest
Option 2 - Boulder Drop w/ Riffle Drop Downstream	Little/None	Moderate	Lowest Impact	IP Required	Moderately Higher
Option 3 - Boulder Drop w/ Riffle Drop Upstream	Little/None	Moderate	Moderate/High Impact	IP Required	Moderately Higher

* - For the drop structures only. Control structures for this project are anticipated to be constructed of concrete and will likely trigger a requirement that the entire project be permitted under an IP rather than under NWP 27.

- **Public Visibility** – Brown and Caldwell considered the visibility of the project improvements from the Shop Creek Trail after a period of 1-2 years. Options 2 and 3 are approximately 400 feet downstream from the trail, where the first drop for Option 1 is approximately 200 feet downstream.
- **Stream Impact** – Brown and Caldwell considered the portion of the stream bend and bank area impacted by the improvements. Due to needing five structures rather than two, the riffle drops have a greater footprint on the streambed initially, but are likely to be less visible after several years when vegetation has accumulated. The advantage of boulder drops is that greater drops are possible in a shorter reach of stream compared to riffle drops, limiting the area of impact to the stream.
- **Construction Impact** – Brown and Caldwell considered the size of the footprint of the structures, the size requirements for construction access and staging immediately adjacent to the construction area, and the impacts of the required construction equipment on the disturbed land and on the surrounding area. Placement of riprap for the riffle drops (Option

1) is judged to be somewhat less of an impact than placement of concrete required for a boulder drop, due to the fewer pieces of large equipment required for the effort. However, the width of the structures and the number of structures increases the overall construction and access footprint associated with this option. Option 3 has the highest impact because of the amount of equipment needed for construction, the size of the staging/working area needed at the riverside area for construction of the boulder drop, and since the boulder drop is located further downstream for Option 3 vs. Option 2, requiring a longer construction access route for the concrete equipment.

- 404 Permitting Issues – The Preble’s mouse issue is common to all three Options. It is possible that an IP will be required regardless of the Option selected, but there is a reasonable possibility that Option 1 will not trigger the need for an IP.
- Relative Cost – Detailed cost estimates are not available at this time; however, based on prior experience, the boulder drops are typically slightly higher in cost than the equivalent riffle drops.

5. ALTERNATIVE SELECTION

Brown and Caldwell met with Tim Metzger from Cherry Creek State Park and Bill Ruzzo, Cherry Creek Basin Water Quality Authority representative, on April 13, 2010 to review the 50-percent submittal document, which included the three alternative options. The basis of the project and the alternatives were presented and discussed. Mr. Metzger took copies of the 50-percent report for further review. The alternative selected for further development was Option 1.

During the meeting, it was discussed that the total drop needed was approximately 5 feet, and that the footprint of the riffle drops was fairly large. Brown and Caldwell offered the option to increase the vertical drop for each structure to 1.25 feet and reduce the number of drops structures. It was decided at that time that the footprint would not be significantly reduced by constructing fewer structures, so that option was not exercised.

The decision to go with the riffle drop structures-only option was made in part due to some of the potential permitting difficulties that may have been encountered if the options including the sloping boulder drops had been selected. In addition, while the riffle drop option creates a larger overall footprint, both in terms of impact on the streambed and access along a much longer reach of the channel, it was pointed out that clearing of trees in the area would likely increase habitat in the vicinity of the project once the construction and restoration work was complete.

A draft of this memorandum and the preliminary design drawings were presented to the Technical Advisory Committee (TAC) on July 1, 2010 for consideration. The TAC agreed with the recommendations made by Brown and Caldwell for the SRP, allowing it to move forward to the CCWQBA Board for approval with only minor comments. Those comments have been incorporated into this final memorandum.

6. HYDRAULIC ANALYSIS

The United States Army Corps of Engineers (USACE) HEC-RAS computer program was used to model the hydraulic profile of Cherry Creek in the vicinity of the project site. Information used for input into the HEC-RAS computer program was gathered from various sources and is described in the following sections.

6.1 Survey and Cross-Section Information

The existing conditions topographic survey data were provided to Brown and Caldwell electronically by Aspen Surveying, Inc. Cross-sections for the HEC-RAS model were taken directly from the survey points. The cross-section geometries can be found in Attachment B.

6.2 Proposed Riffle Drops

The five proposed riffle drops were input into the HEC-RAS model using the preliminary plan drawings. Each riffle drop was input as four cross-sections that represent the major design points of the drops. The channel slope between riffle drops was set at the stable channel slope of 0.0022 ft/ft. Cross-section geometries for the riffle drops can be found in Figure 1.

6.3 Design Flow

The design flow selected for use in preliminary design was 225 cfs. The channel in the project reach has a much higher flow conveyance capacity (400 cfs or more) than the design flow rate, but the capacity of the channel in the reach upstream from the Shop Creek Foot Bridge is the limiting factor. The capacity of the channel in the upstream reach is approximately 200 cfs, and the general topography of the overbank areas indicates that flows that leave the main channel tend to sheet flow toward the reservoir without returning to the main channel unless the flow reaches minor side channels that are tributary to the main channel. The design flow was set at 225 cfs to account for the flow remaining in the channel through the upstream reach plus a return flow from overbank areas of approximately ten percent of the channel flow.

6.4 Boundary Conditions

The starting water surface elevation for Cherry Creek was determined by allowing the HEC-RAS computer program to compute a normal depth elevation for the design flow. The downstream slope, which was used in the normal depth computations, was estimated from the existing topographic information.

6.5 Manning's Roughness Coefficients

Manning's Roughness Coefficients were determined from photographs taken during site visits by Brown and Caldwell and from aerial photographs. The coefficients were determined using Table 3.1 in the HEC-RAS Hydraulic Reference Manual. The over bank areas consist of grassy vegetation and trees and were, therefore, assigned a roughness of 0.035. Alternatively, the Cherry Creek channel is very sandy and was assigned a roughness of 0.025.

6.6 Final Hydraulic Results

Two plans were run for the model: one with existing conditions and one with the proposed riffle drops.

As a result of the proposed project the stream hydraulics were beneficially altered in many ways. The maximum channel velocities decreased from a maximum of 7.4 ft/s to a maximum of 6.3 ft/s in the project reach. Additionally the project decreases shear stress from a maximum of 0.83 lbs/ft² to maximum shear stress of 0.66 lbs/ft². Finally, as would be expected, the proposed project lowers the average water depth within the project reach from approximately 4 feet to 2.8 feet. The complete HEC-RAS model input and output can be found in Attachments D and E, respectively.

In the lower reach, there are no significant hydraulic changes made to the channel. Since this channel is modeled using a backflow analysis, there are no significant changes in the model results; with the velocity and

shear parameters similar to those for the post-project conditions in the upper reach, listed above.

7. DESIGN DETAILS

The preliminary drawings for the design are attached, showing the overall project area, including staging for construction, the proposed layout of the riffle drops along the stream, and design and layout information for the individual riffle drop structures. Also attached are estimates for construction quantities and costs.

7.1 Construction Impacts

The riffle drops are oval-shaped riprap drop structures with a drop face slope of 20:1 (5%) down to a small, shallow pool at the base of the drop. The pool is formed by a run-up face at the lower end of the drop, typically at an adverse slope of 10 percent.

For the preliminary design, all five riffle drops are designed using the same configuration. The side slopes for this project are set at 4:1 to avoid creating a wide drop that would significantly increase the footprint of the project due to the depth of the highly incised channel in this area. The configuration of the drop is set so that the vertical drop is 1.0 foot from the crest elevation at the upstream end of the drop to the crest of the run-up section at the toe of the drop structure. The depth of the pool is 0.6 feet at its deepest point.

The drops measure 72 feet wide (perpendicular to the channel) and 45 feet long. They are placed at 95-foot centers along the upper reach of the channel, starting just downstream from the City of Aurora pipe protection structure that was recently constructed near the Shop Creek Trail Bridge. The lowest drop structure terminates upstream from a small, unnamed tributary from the west, where the slope of the existing channel is at a naturally more stable slope.

The construction of the drop structures will require cutting and filling for the entire 600-foot length of the impacted reach of the channel, to bring the channel to grade and to construct the riffle drops as designed. Due to the existing channel cross-section being highly incised through the reach, there will be a significant cut required to lay back the bank slopes to the 4:1 slopes used for the riffle drops. The total cut volume is calculated to be approximately 4300 cubic yards, while the fill volume will be approximately 400 cubic yards, resulting in a net cut of 3900 cubic yards. Subtracting out the volumes of imported construction materials, and an allowance for a minimal amount of on-site disposal with the bulk of excess cut material being hauled off site for disposal or use elsewhere, the result will be a net increase in the water storage volume available in the upper reservoir pool area of approximately 0.8 acre-feet. See Table 7-1 for a tabulation of the calculated volumes of construction materials to be excavated/placed on site, and Attachment F for the spreadsheet used to calculate the earthwork volumes for work in the channel.

Table 7-1 Cut/Fill Volumes

	Channel Excavation	Channel Fill	Imported Materials *	Minimum Export to Off-Site Areas	On Site Disposal Allowed
Calculated Volumes	4300 cy	400 cy	2400 cy	1300 cy	200 cy

* - Includes 900 cy for road base and road surfacing materials, 1475 cy of riprap and bedding for drop structures and channel lining, and 25 cy of concrete for control structures and cutoff wall.

Only minor bank stabilization work is anticipated downstream from this point, with the exception being a 'hard point' invert control structure, located near the Wetlands Bridge. The purpose of the 'hard point' is to create a stable point in the streambed to prevent any headcutting in the bed from the downstream reach migrating upstream into the project area, and to minimize the erosion and transport of soils to the lower reach and into the reservoir.

7.2 Construction Access

Access to the channel for construction of the drop structures in the upper end of the reach will be via the existing trail/road extending west from the Shop Creek Trail foot bridge. This route has an existing, improved road surface, with good clearance for construction equipment, and was used for the City of Aurora project water line protection project, just downstream from the bridge. Little or no additional impact to the Park's natural areas and little or no restoration would be required along this access route.

Once reaching the stream, access to the length of the stream channel required for construction of the drop structures would be in the overbank area on the west side of the creek. This area would also be available for on-site staging of materials and equipment. There is no existing trail in this area, so extensive site restoration will be required. The access and construction area will extend approximately 100-125 feet to the west of the channel centerline. Most of the trees and vegetation in this corridor along the side of the riffle drops will be removed or disturbed.

Access to the lower section of the project, at the Wetlands Trail foot bridge, will be from the east side of the creek. There is an existing, narrow trail that extends to the east from the bridge through a forested area for approximately 250 feet, opening into a grassy area, where there is a wide asphalt trail running toward the Shop Creek Trail parking area. The trail through the forest area will have to be widened and the surface improved to be suitable for construction traffic, but the disturbed area is much less than would be possible from the west side of the creek.

All disturbed areas along the stream and along the access to the construction areas will be restored with native plantings and sprigging of willows (where appropriate). Planting of new trees for this project is not anticipated.

7.3 Construction Cost Opinion

Based on the preliminary design layout for the project, and using cost data from the Urban Drainage and Flood Control District and RS Means Construction Cost Data, the cost for construction is anticipated to be approximately \$675,000, including a 30% construction cost contingency. This amount also includes costs for final design, a design re-survey, project permitting, and part-time construction observation. See Table 7-2 for a summary breakdown of the Engineer's Cost Opinion.

Table 7-2 Engineer's Opinion of Probable Cost for Stream Reclamation (Recommended Option)

Cherry Creek at Shop Creek Trail

Cost Items	Quantity	Units	Unit Cost	Total Cost	Notes
1 Mobilization/De-Mobilization Includes BMPs for Stormwater and Sediment Control	1	LS	39800.00	\$ 39,800	Use 10% of construction costs for Items 2 through 11
2 Site Preparation Clearing and Grubbing of Work and Staging Areas Includes Cutting and Removing Trees	5.2	AC	10500.00	\$ 54,600	Cost per acre w/ premium for large number of trees Includes removal and disposal of woody material
3 Access Road Preparation Road Sub-Base Prep and Gavel Surfacing	24000	SF	1.50	\$ 36,000	Use 20-ft road width west side of creek, 10-ft for east side Cost per square foot
4 Temporary Trail Rerouting Crushed Gravel Surfacing for Temporary Trail	800	SF	0.85	\$ 680	Estimated length of 4-ft wide temporary trail, cost per square foot
5 Stream Diversion Temporary Diversion Dam on Stream (incl removal)	220	CY	25.00	\$ 5,500	3-ft high embankment above top of bank, cost per cubic yard
Pipe Conveyance (48" RCP pipe)	600	LF	150.00	\$ 90,000	Pipe placed in partial depth (2.5 ft deep) trench, cost per linear foot
Pipe Capacity Sized at 75% of 225 cfs Stream Channel Design Flow					
6 Earthwork Excavation for Channel Construction	4300	CY	5.50	\$ 23,650	Including cut for placement of riprap and bedding, cost per cubic yard
Common Fill for Channel Construction	400	CY	7.00	\$ 2,800	Use on-site material for all fill requirements, cost per cubic yard
Haul and Dispose of Excess Cut Material	3900	CY	12.00	\$ 46,800	Includes loading, hauling and off-site disposal of clean material, cost per cubic yard
7 Riprap and Bedding Type H (D=18") Riprap for Structures	960	CY	60.00	\$ 57,600	Use t = 1.75 D for volume of riprap, cost per cubic yard
Type M (D=12") Riprap for Channel Protection for New Channel	340	CY	53.00	\$ 18,020	Use t = 1.75 D for volume of riprap, cost per cubic yard
Bedding Material	170	CY	58.50	\$ 9,945	Use t = 1.0 ft, cost per cubic yard
8 Concrete Control Structures (2 total)	18	CY	360.00	\$ 6,480	Formed, buried wall 12" wide by 36" deep, cost per cubic yard
9 Concrete Cutoff Curb	200	LF	7.50	\$ 1,500	6" wide x 18" high curb, bury all but upper 2-3 inches, cost per linear foot
10 Fencing	270	LF	80.00	\$ 21,600	Massive rail fence along trail near drop structures, and at Shop Creek Trail parking area (access point for work at Wetlands Trail bridge) cost per linear foot
11 Site Restoration Revegetation of Site, Including Staging and Access Areas					
Upland Areas	4.8	AC	4000.00	\$ 19,200	Native grass vegetation in upland areas, cost per acre
Channel Bank Revegetation	0.4	AC	9000.00	\$ 3,600	Riparian species in channel areas, including willow sprigging, cost per acre
			SUBTOTAL	\$ 437,775	
			Contingency	\$ 131,300	30% Construction Contingency
			TOTAL CONSTRUCTION COSTS	\$ 569,000	
			Final Design Engineering (incl survey)	\$ 63,400.00	
			Project Permitting	\$ 14,200.00	
			Construction Observation (part-time)	\$ 28,500.00	
			TOTAL PROJECT COSTS *	\$ 675,000	

* - Not including Project Administration

8. SUMMARY

Five riffle drops are proposed for the project area. The riffle drops will be located from approximately 700-250 feet downstream of the existing Shop Creek Trail Bridge. Each of the five riffle drops will provide approximately one foot of drop, for a combined drop of approximately five feet. This will provide the necessary drop in order to return the Cherry Creek channel to the stable slope of 0.0022 ft/ft.

9. RECOMMENDATIONS

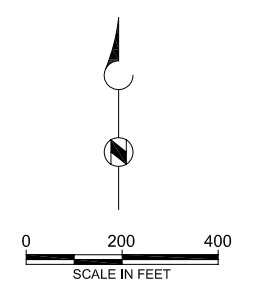
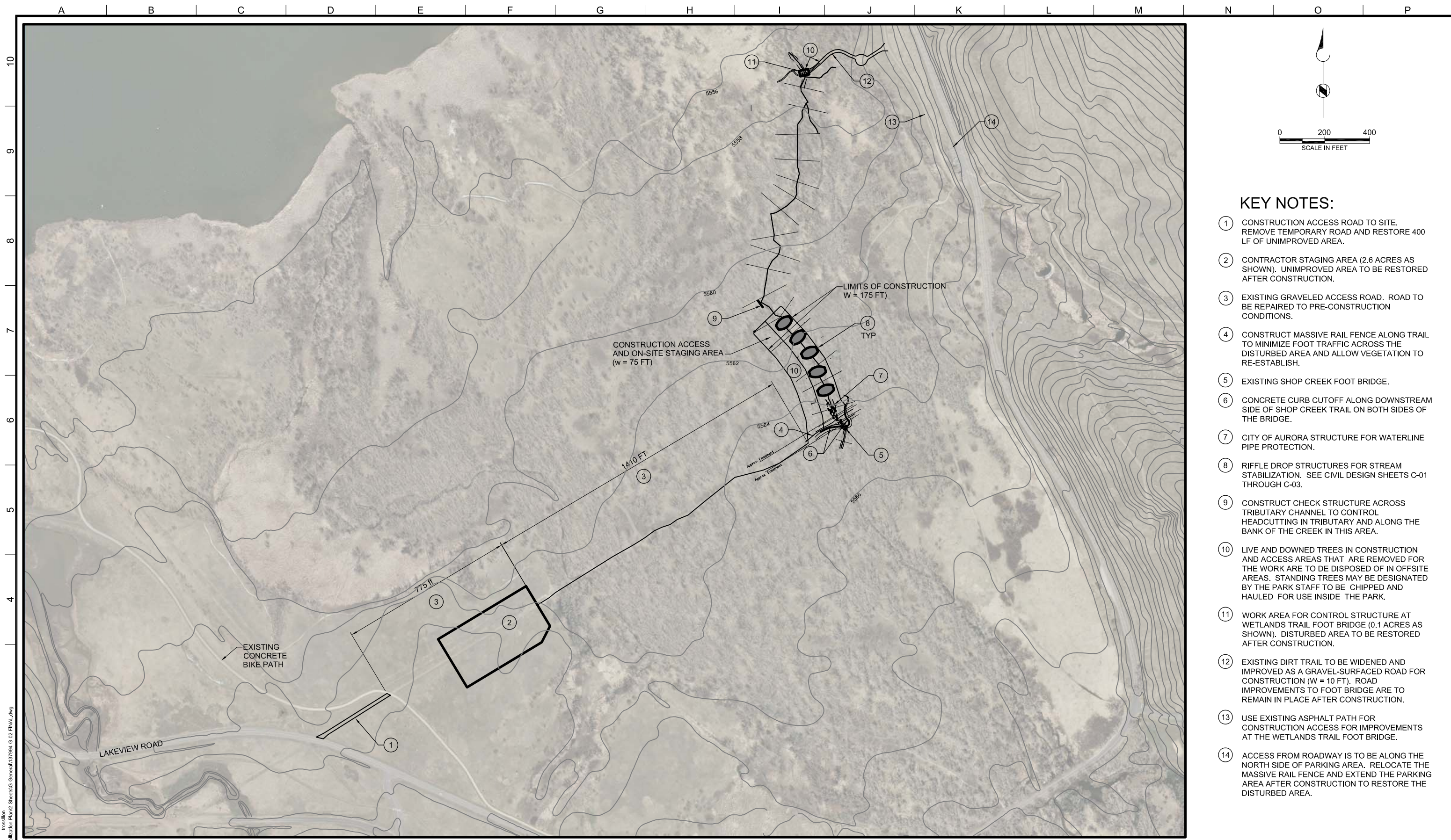
Brown and Caldwell makes the following recommendations for further action on this project.

- Construct five riffle drops (one-foot drop each) in the upper reach of the project area.
- Construct bridge abutments with a control structure across the channel just downstream from the existing Wetlands Trail Bridge.
- Construct a control structure across the tributary to the main channel just downstream from of the last drop structure.
- Construct cutoff curb immediately downstream from the Shop Creek Trail, extending approximately 100 feet (more or less) in each direction from the bridge abutments.
- Leave existing Wetlands Trail Bridge in place to maintain access until new bridge can be put in service at new location.
- Coordinate the design of the new Wetlands Trail Bridge abutments and control structure with the Park staff for bridge sizing and schedule for installation.
- Coordinate relocation of the stream monitoring station from just downstream from the Wetlands Trail Bridge to the new control structure for more accurate readings.
- Access the drop structure construction area from the west, using the existing trail maintenance road leading to the Shop Creek Bridge. Also, use the same staging area used for the City of Aurora waterline protection project.
- Clear the construction access and staging area for drop structure construction on the west side of the creek. Remove and chip standing trees, and remove downed trees and debris for disposal.
- Coordinate disposal of waste materials from construction with the Park; some may be useful at other locations within the Park.

- Dispose of materials not stockpiled for use by the Park off site or (in limited quantities) in areas designated by Park staff.
- Divert flow in the creek temporarily during construction using partially buried RCP on the east side of the creek for work on the drop structures.
- Access the work at the Wetlands Trail Bridge from the east, following the existing trails from the Shop Creek Trail parking area.
- Revegetate all disturbed areas with approved riparian and upland seed mixes (as appropriate); planting trees is not required.
- Construct a massive rail fence along the Shop Creek trail west of the bridge to the west edge of the cleared construction access area to minimize foot traffic.
- Extend parking at the Shop Creek Trail parking area to cover construction access disturbance just to the north of the existing parking area; extend and relocate massive rail fence for the enlarged parking area.
- Plan and schedule time for obtaining an Individual Permit for the project, including time for ESA review for the Preble's Meadow Jumping Mouse; incorporate comments from agencies into final design.

10. STREAM STABILIZATION PLAN SET





KEY NOTES:

- 1 CONSTRUCTION ACCESS ROAD TO SITE. REMOVE TEMPORARY ROAD AND RESTORE 400 LF OF UNIMPROVED AREA.
- 2 CONTRACTOR STAGING AREA (2.6 ACRES AS SHOWN). UNIMPROVED AREA TO BE RESTORED AFTER CONSTRUCTION.
- 3 EXISTING GRAVELED ACCESS ROAD. ROAD TO BE REPAIRED TO PRE-CONSTRUCTION CONDITIONS.
- 4 CONSTRUCT MASSIVE RAIL FENCE ALONG TRAIL TO MINIMIZE FOOT TRAFFIC ACROSS THE DISTURBED AREA AND ALLOW VEGETATION TO RE-ESTABLISH.
- 5 EXISTING SHOP CREEK FOOT BRIDGE.
- 6 CONCRETE CURB CUTOFF ALONG DOWNSTREAM SIDE OF SHOP CREEK TRAIL ON BOTH SIDES OF THE BRIDGE.
- 7 CITY OF AURORA STRUCTURE FOR WATERLINE PIPE PROTECTION.
- 8 RIFFLE DROP STRUCTURES FOR STREAM STABILIZATION. SEE CIVIL DESIGN SHEETS C-01 THROUGH C-03.
- 9 CONSTRUCT CHECK STRUCTURE ACROSS TRIBUTARY CHANNEL TO CONTROL HEADCUTTING IN TRIBUTARY AND ALONG THE BANK OF THE CREEK IN THIS AREA.
- 10 LIVE AND DOWNED TREES IN CONSTRUCTION AND ACCESS AREAS THAT ARE REMOVED FOR THE WORK ARE TO BE DISPOSED OF IN OFFSITE AREAS. STANDING TREES MAY BE DESIGNATED BY THE PARK STAFF TO BE CHIPPED AND HAULED FOR USE INSIDE THE PARK.
- 11 WORK AREA FOR CONTROL STRUCTURE AT WETLANDS TRAIL FOOT BRIDGE (0.1 ACRES AS SHOWN). DISTURBED AREA TO BE RESTORED AFTER CONSTRUCTION.
- 12 EXISTING DIRT TRAIL TO BE WIDENED AND IMPROVED AS A GRAVEL-SURFACED ROAD FOR CONSTRUCTION (W = 10 FT). ROAD IMPROVEMENTS TO FOOT BRIDGE ARE TO REMAIN IN PLACE AFTER CONSTRUCTION.
- 13 USE EXISTING ASPHALT PATH FOR CONSTRUCTION ACCESS FOR IMPROVEMENTS AT THE WETLANDS TRAIL FOOT BRIDGE.
- 14 ACCESS FROM ROADWAY IS TO BE ALONG THE NORTH SIDE OF PARKING AREA. RELOCATE THE MASSIVE RAIL FENCE AND EXTEND THE PARKING AREA AFTER CONSTRUCTION TO RESTORE THE DISTURBED AREA.

Dec 03, 2010 - 1:14pm
 P:\2010\Cherry Creek\137994_Shaman\Sham\Stabilization Plan\2-Sheets\C-General\137994-G-02-FINAL.dwg

Brown and Caldwell
DENVER, COLORADO

LINE IS 2 INCHES
AT FULL SIZE
(IF NOT 2" - SCALE ACCORDINGLY)

DESIGNED: _____
DRAWN: GEM
CHECKED: _____
CHECKED: _____
APPROVED: TR

EXTERNAL REFERENCE FILES	
CCBWQA_Logo.jpg	
27611697.rtf	
8-25-09_AU11-C001.jpg	
BC_1Va_L_P_(GFP).bmp	
CCBWQA_Master.jpg	
Browncaldwell.jpg	
CCBWQA_Logo.jpg	
27611697.rtf	
8-25-09_AU11-C001.jpg	
BC_1Va_L_P_(GFP).bmp	
CCBWQA_Master.jpg	

SUBMITTED: _____ DATE: _____
PROJECT MANAGER

APPROVED: _____ DATE: _____
BROWN AND CALDWELL

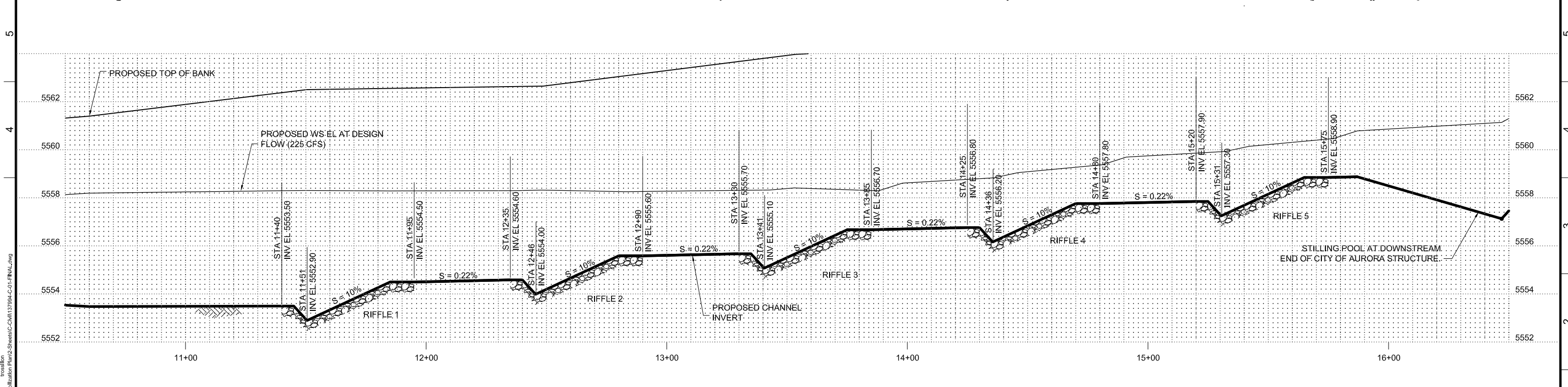
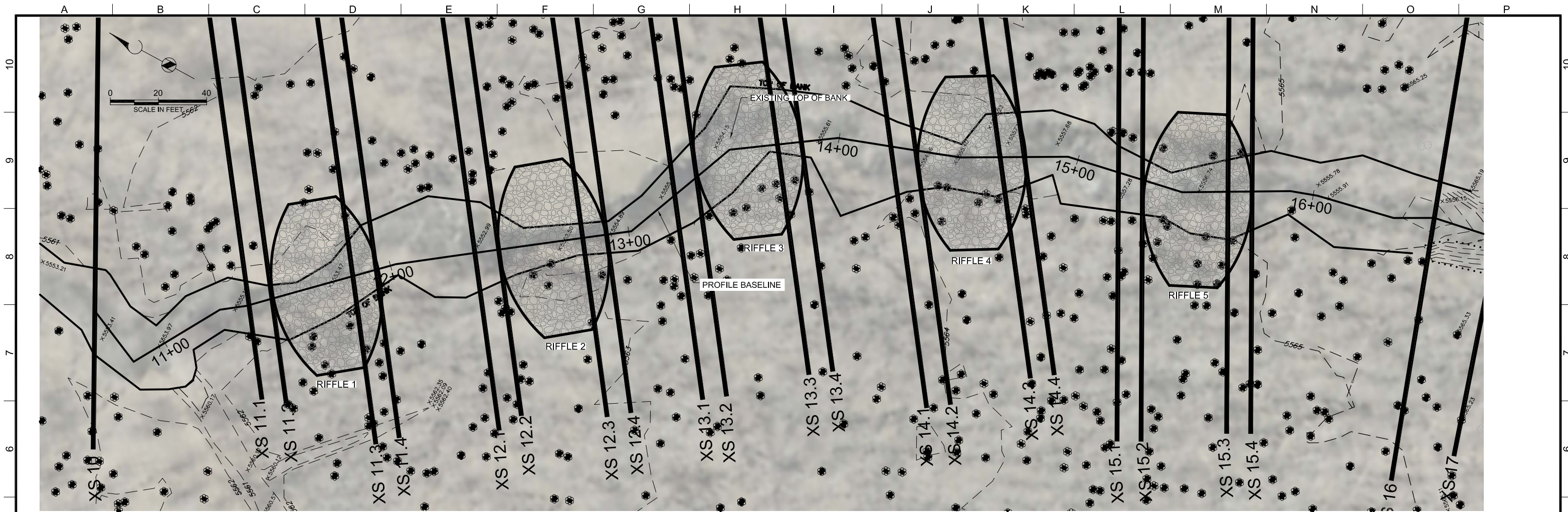
REVISIONS					
ZONE	REV.	DESCRIPTION	BY	DATE	APP.



CHERRY CREEK AT SHOP CREEK TRAIL
STREAM STABILIZATION PLAN

OVERVIEW/ACCESS PLAN

FILENAME	137994-G-02-FINAL
BC PROJECT NUMBER	137994
CLIENT PROJECT NUMBER	
DRAWING NUMBER	G-02
SHEET NUMBER	2 OF 6



Dec 03, 2010 - 11:41am
 P:\2010\Cherry Creek\137994_Stream_Stabilization_Plan\2-Sheets\C-01-FINAL.dwg
 I:\osullivan

Brown and Caldwell
DENVER, COLORADO

SUBMITTED: _____ DATE: _____
 PROJECT MANAGER
 APPROVED: _____ DATE: _____
 BROWN AND CALDWELL

LINE IS 2 INCHES
 AT FULL SIZE
 (IF NOT 2" - SCALE ACCORDINGLY)
 DESIGNED:
 DRAWN: GEM
 CHECKED:
 CHECKED:
 APPROVED: TR

EXTERNAL REFERENCE FILES

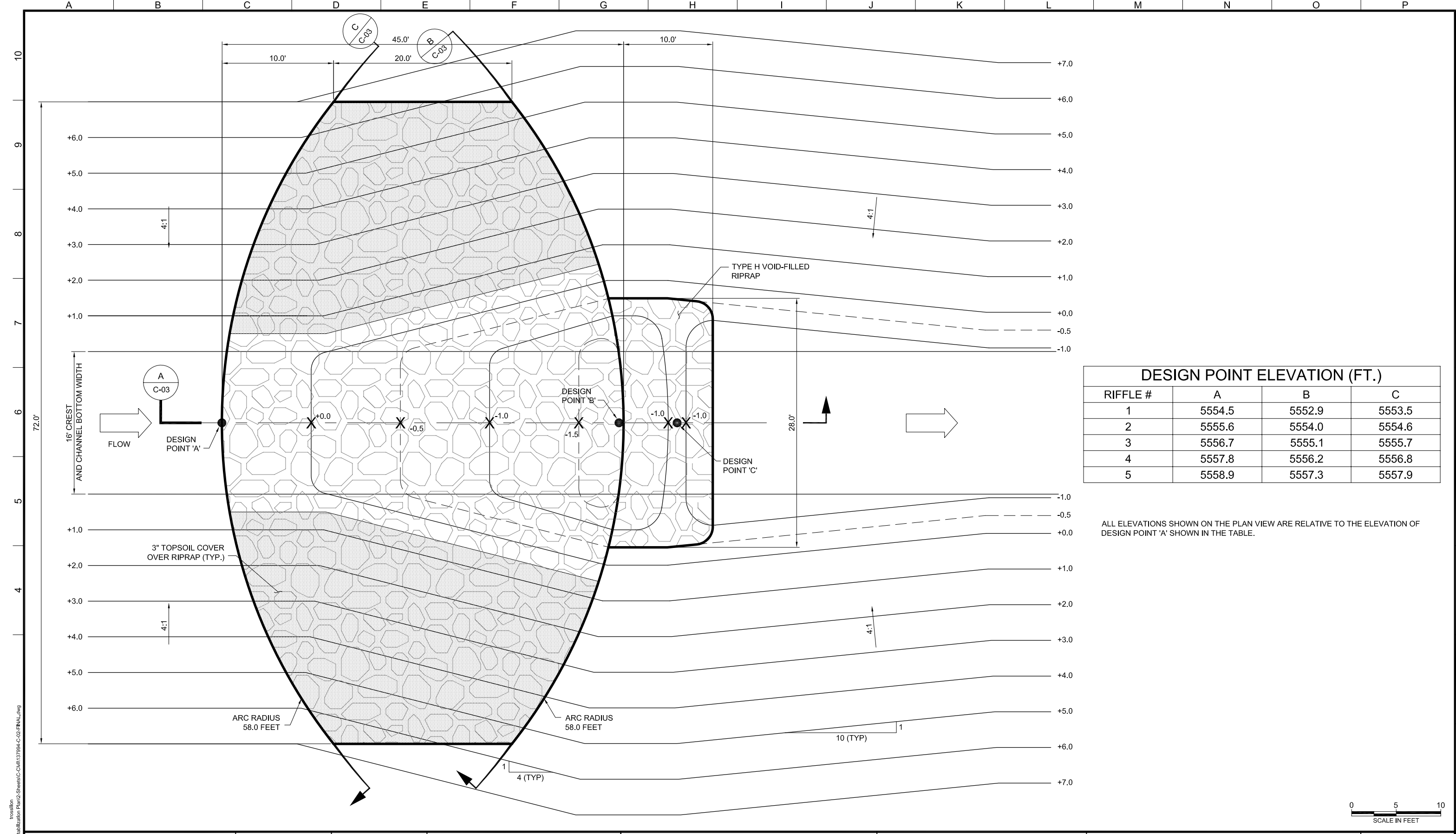
REVISIONS					
ZONE	REV.	DESCRIPTION	BY	DATE	APP.



CHERRY CREEK AT SHOP CREEK TRAIL
 STREAM STABILIZATION PLAN

**STREAM STABILIZATION
 PLAN AND PROFILE**

FILENAME
 137994-C-01-FINAL
 BC PROJECT NUMBER
 137994
 CLIENT PROJECT NUMBER
 DRAWING NUMBER
C-01
 SHEET NUMBER
 3 OF 6



DESIGN POINT ELEVATION (FT.)			
RIFFLE #	A	B	C
1	5554.5	5552.9	5553.5
2	5555.6	5554.0	5554.6
3	5556.7	5555.1	5555.7
4	5557.8	5556.2	5556.8
5	5558.9	5557.3	5557.9

ALL ELEVATIONS SHOWN ON THE PLAN VIEW ARE RELATIVE TO THE ELEVATION OF DESIGN POINT 'A' SHOWN IN THE TABLE.

Dec 03, 2010 - 1:51 pm
 P:\CAD\Cherry Creek\137994_Stream_Stabilization_Plan\2-Sheets\C-02\FINAL.dwg
 I:\rosillon

Brown and Caldwell
DENVER, COLORADO

LINE IS 2 INCHES
AT FULL SIZE
(IF NOT 2" - SCALE ACCORDINGLY)

DESIGNED:
DRAWN: GEM
CHECKED:
CHECKED:
APPROVED: TR

EXTERNAL REFERENCE FILES
CCBWQA_Logs.dwg

REVISIONS					
ZONE	REV.	DESCRIPTION	BY	DATE	APP.



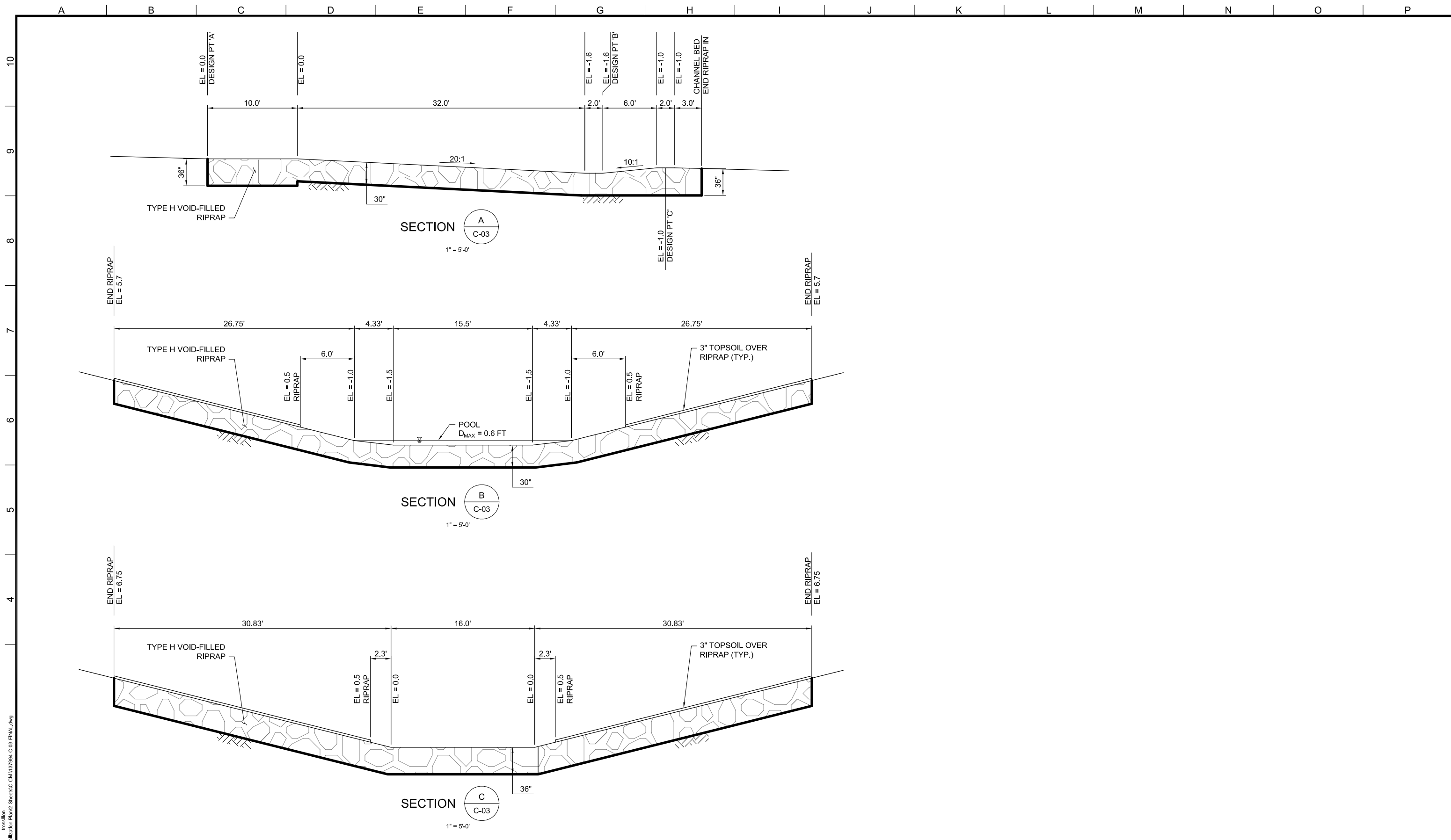
CHERRY CREEK AT SHOP CREEK TRAIL
STREAM STABILIZATION PLAN

RIFFLE DROP STRUCTURES
TYPICAL PLAN

FILENAME
137994-C-02-FINAL
BC PROJECT NUMBER
137994
CLIENT PROJECT NUMBER

DRAWING NUMBER
C-02
SHEET NUMBER
4 OF 6

A B C D E F G H I J K L M N O P



Dec 03, 2010 - 1:53pm
 P:\CAD\00Cherry Creek\137994 Stream Stabilization Plans\Sheet\C-03\FINAL.dwg
 I:\rosillon

Brown and Caldwell
DENVER, COLORADO

SUBMITTED: _____ DATE: _____
 PROJECT MANAGER

APPROVED: _____ DATE: _____
 BROWN AND CALDWELL

LINE IS 2 INCHES
AT FULL SIZE
(IF NOT 2" - SCALE ACCORDINGLY)

DESIGNED:
DRAWN: GEM
CHECKED:
CHECKED:
APPROVED: TR

EXTERNAL REFERENCE FILES
CCBWQA_Logs.dwg

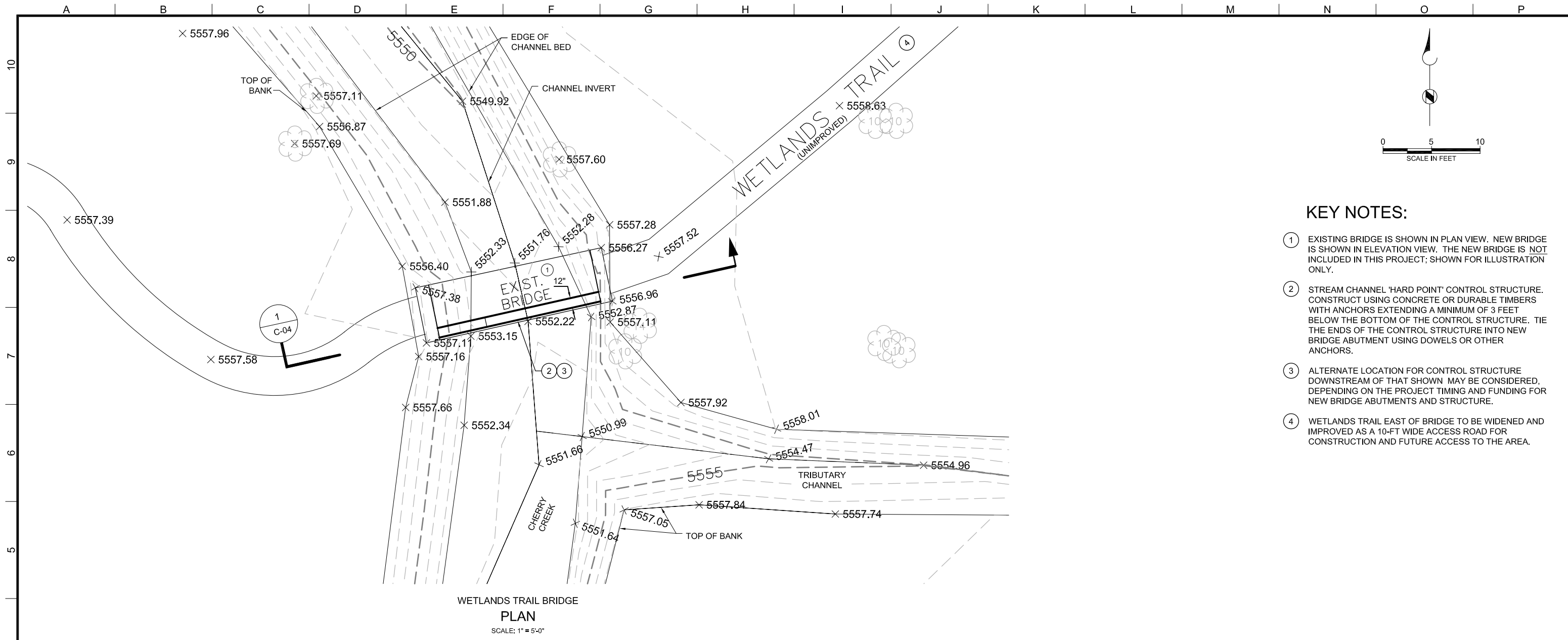
REVISIONS					
ZONE	REV.	DESCRIPTION	BY	DATE	APP.



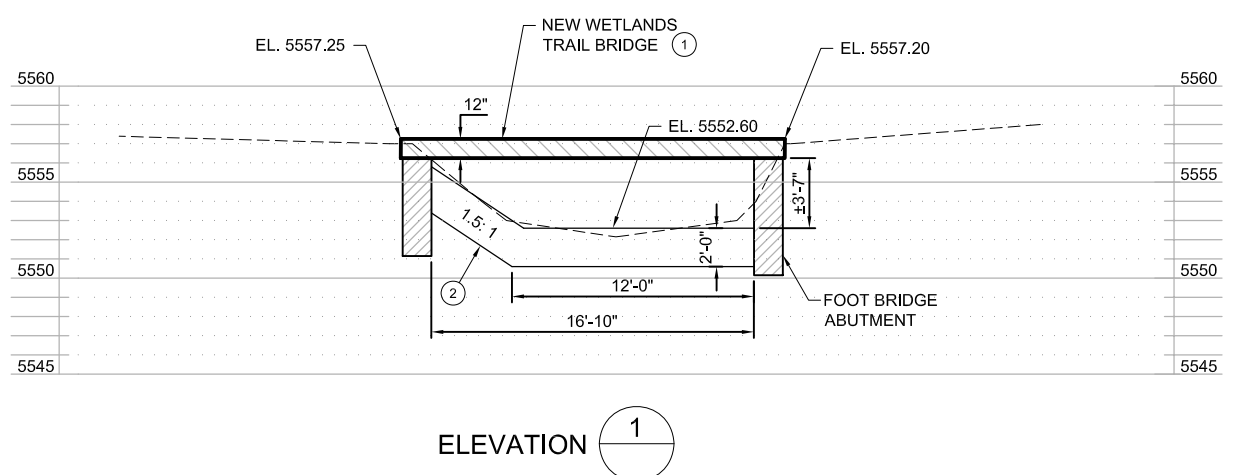
CHERRY CREEK AT SHOP CREEK TRAIL
STREAM STABILIZATION PLAN

**RIFFLE DROP STRUCTURES
TYPICAL SECTIONS**

FILENAME 137994-C-03-FINAL
BC PROJECT NUMBER 137994
CLIENT PROJECT NUMBER
DRAWING NUMBER C-03
SHEET NUMBER 5 OF 6



- KEY NOTES:**
- EXISTING BRIDGE IS SHOWN IN PLAN VIEW. NEW BRIDGE IS SHOWN IN ELEVATION VIEW. THE NEW BRIDGE IS NOT INCLUDED IN THIS PROJECT; SHOWN FOR ILLUSTRATION ONLY.
 - STREAM CHANNEL 'HARD POINT' CONTROL STRUCTURE. CONSTRUCT USING CONCRETE OR DURABLE TIMBERS WITH ANCHORS EXTENDING A MINIMUM OF 3 FEET BELOW THE BOTTOM OF THE CONTROL STRUCTURE. TIE THE ENDS OF THE CONTROL STRUCTURE INTO NEW BRIDGE ABUTMENT USING DOWELS OR OTHER ANCHORS.
 - ALTERNATE LOCATION FOR CONTROL STRUCTURE DOWNSTREAM OF THAT SHOWN. MAY BE CONSIDERED, DEPENDING ON THE PROJECT TIMING AND FUNDING FOR NEW BRIDGE ABUTMENTS AND STRUCTURE.
 - WETLANDS TRAIL EAST OF BRIDGE TO BE WIDENED AND IMPROVED AS A 10-FT WIDE ACCESS ROAD FOR CONSTRUCTION AND FUTURE ACCESS TO THE AREA.



NOTE:
THE CAPACITY OF THE CHANNEL UNDER THE LOW CHORD OF THE BRIDGE AS SHOWN IS 225 CFS. (DESIGN DATA: n = 0.035, s = 0.30%)

I:\rosalind\137994-Cherry Creek\137994-Stream\Stabilization Plan\2-Sheets\C-04\137994-C-04-FINAL.dwg
 Dec 03, 2010 - 1:53am
 PCAD\02\Cherry Creek\137994-Stream\Stabilization Plan\2-Sheets\C-04\137994-C-04-FINAL.dwg

Brown and Caldwell
DENVER, COLORADO

SUBMITTED: _____ DATE: _____
PROJECT MANAGER

APPROVED: _____ DATE: _____
BROWN AND CALDWELL

LINE IS 2 INCHES AT FULL SIZE (IF NOT 2" - SCALE ACCORDINGLY)

DESIGNED: _____
DRAWN: GEM
CHECKED: _____
CHECKED: _____
APPROVED: TR

EXTERNAL REFERENCE FILES	
CCBWQA_Logs.dwg	

REVISIONS					
ZONE	REV.	DESCRIPTION	BY	DATE	APP.

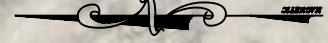
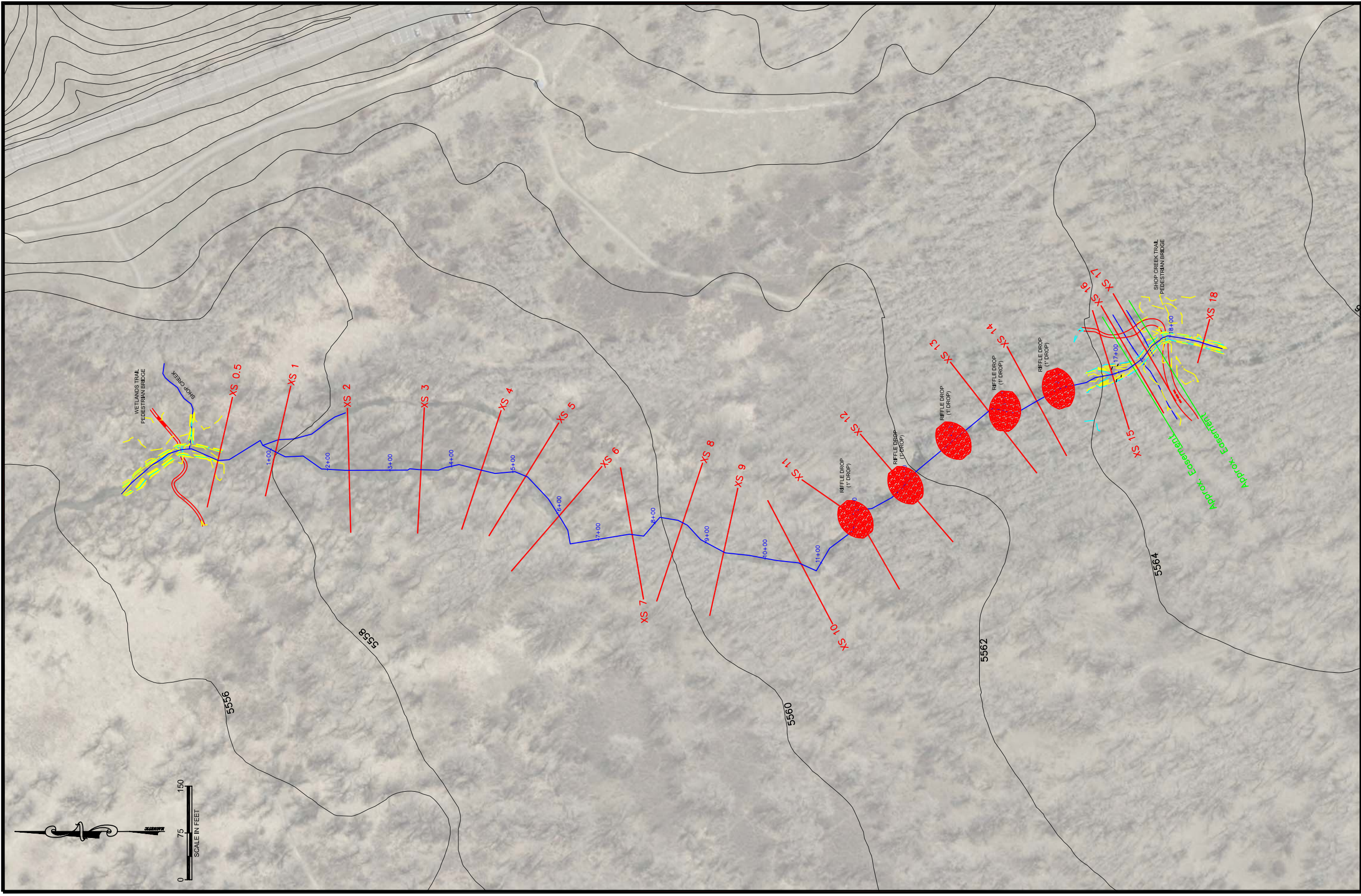


CHERRY CREEK AT SHOP CREEK TRAIL
STREAM STABILIZATION PLAN

**STREAM STABILIZATION
WETLANDS BRIDGE HARD POINT**

FILENAME 137994-C-04-FINAL
BC PROJECT NUMBER 137994
CLIENT PROJECT NUMBER
DRAWING NUMBER C-04
SHEET NUMBER 6 OF 6

11. MEMORANDUM FIGURES



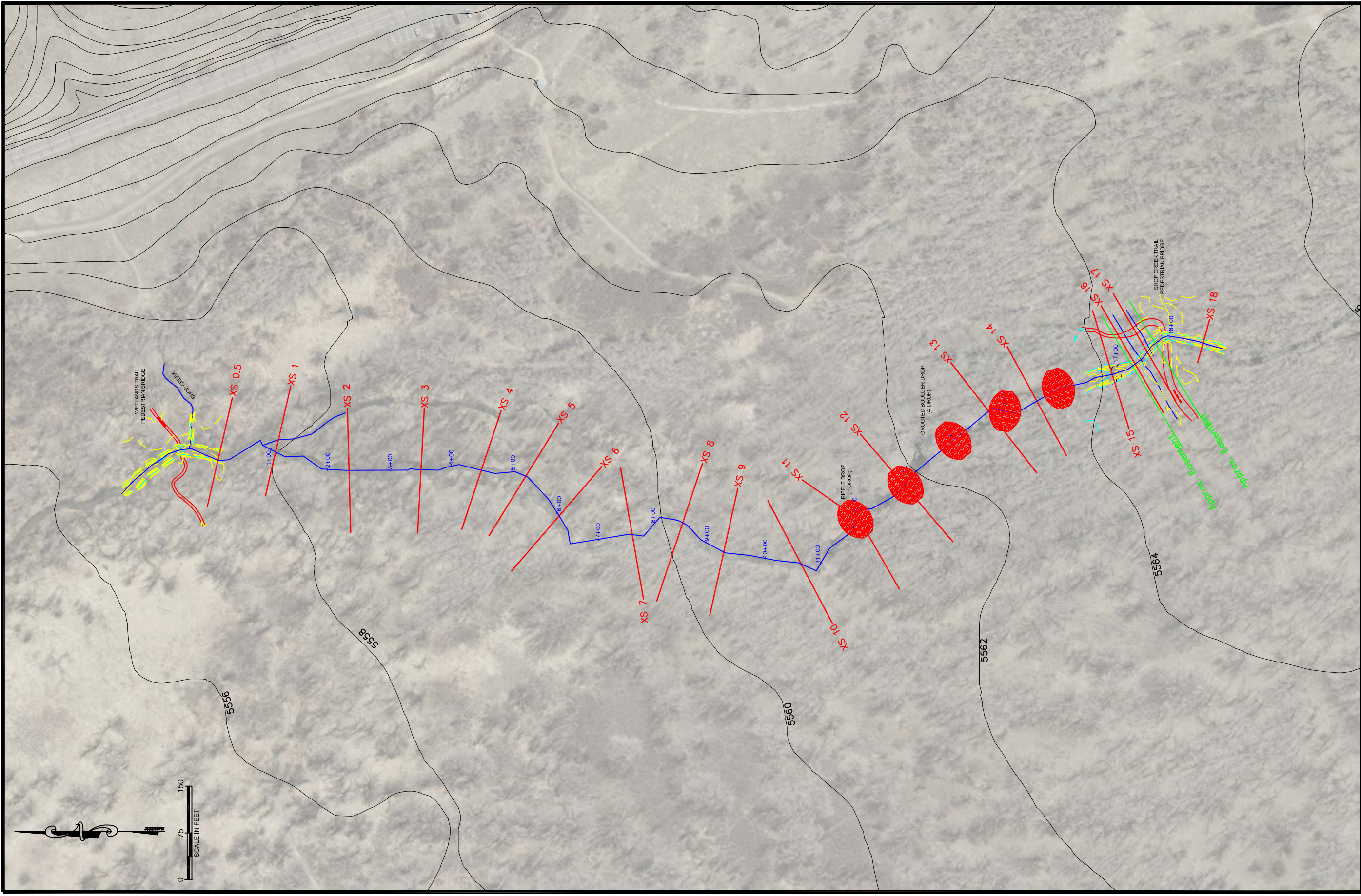
P:\DATA\GEN\CBCB\WQA\13794 CC AT SHOP CR TRAIL\DRAWINGS\ CC MAY10_JW.DWG
 LAST SAVED:5/13/2010 12:27:26 PM



BROWN AND CALDWELL

CHERRY CREEK BASIN WATER QUALITY AUTHORITY
 CHERRY CREEK AT SHOP CREEK TRAIL
 STREAM STABILIZATION PLAN
 PLAN VIEW - OPTION 1

FIGURE 1



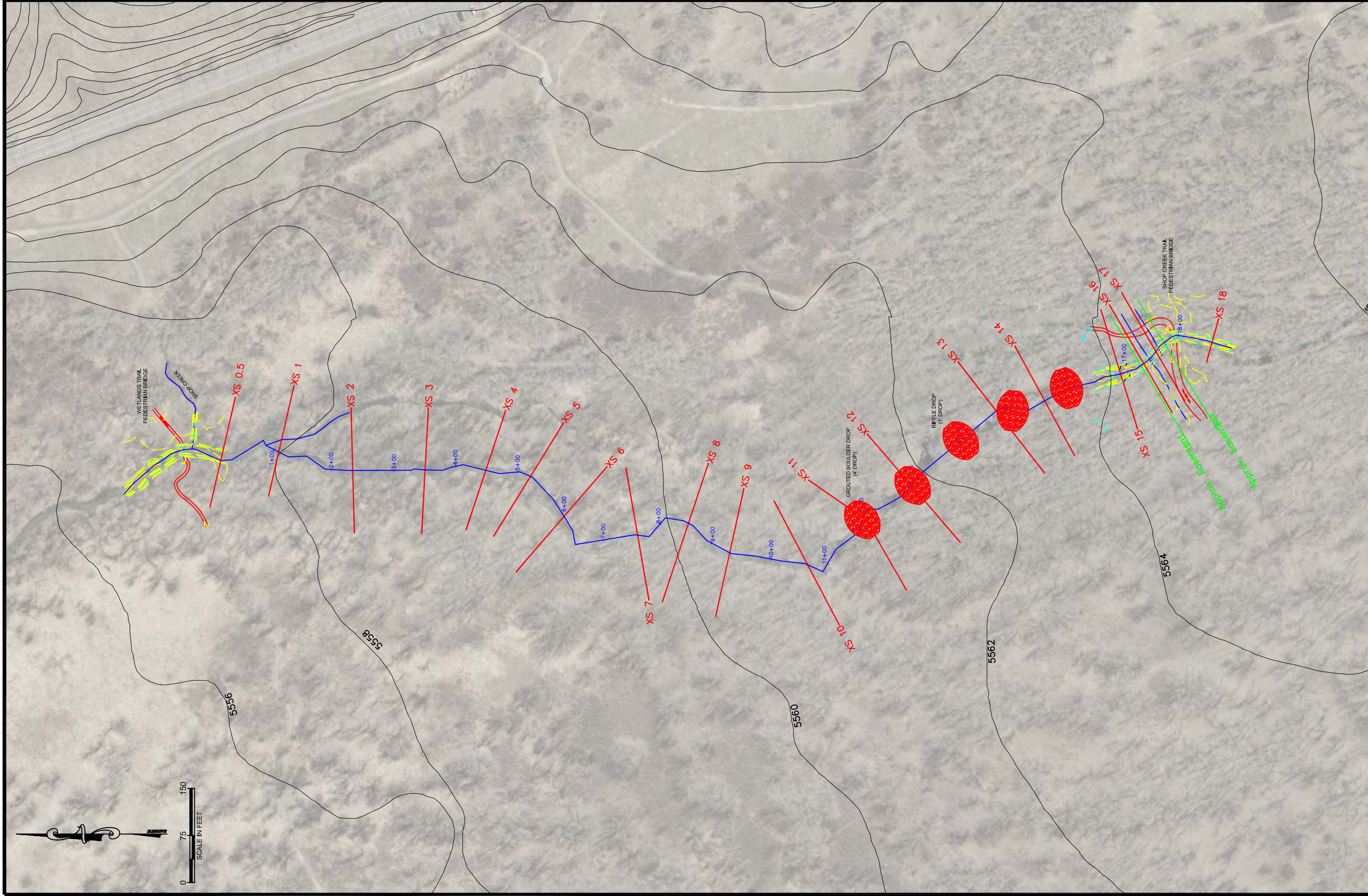
P:\DATA\GEN\C\B\WQA\137994 CC AT SHOP CR TRAIL\DRAWINGS\ CC MAY10_JW.DWG
 LAST SAVED:5/13/2010 12:27:26 PM



BROWN AND CALDWELL

CHERRY CREEK BASIN WATER QUALITY AUTHORITY
 CHERRY CREEK AT SHOP CREEK TRAIL
 STREAM STABILIZATION PLAN
 PLAN VIEW - OPTION 2

FIGURE 2



BROWN AND CALDWELL

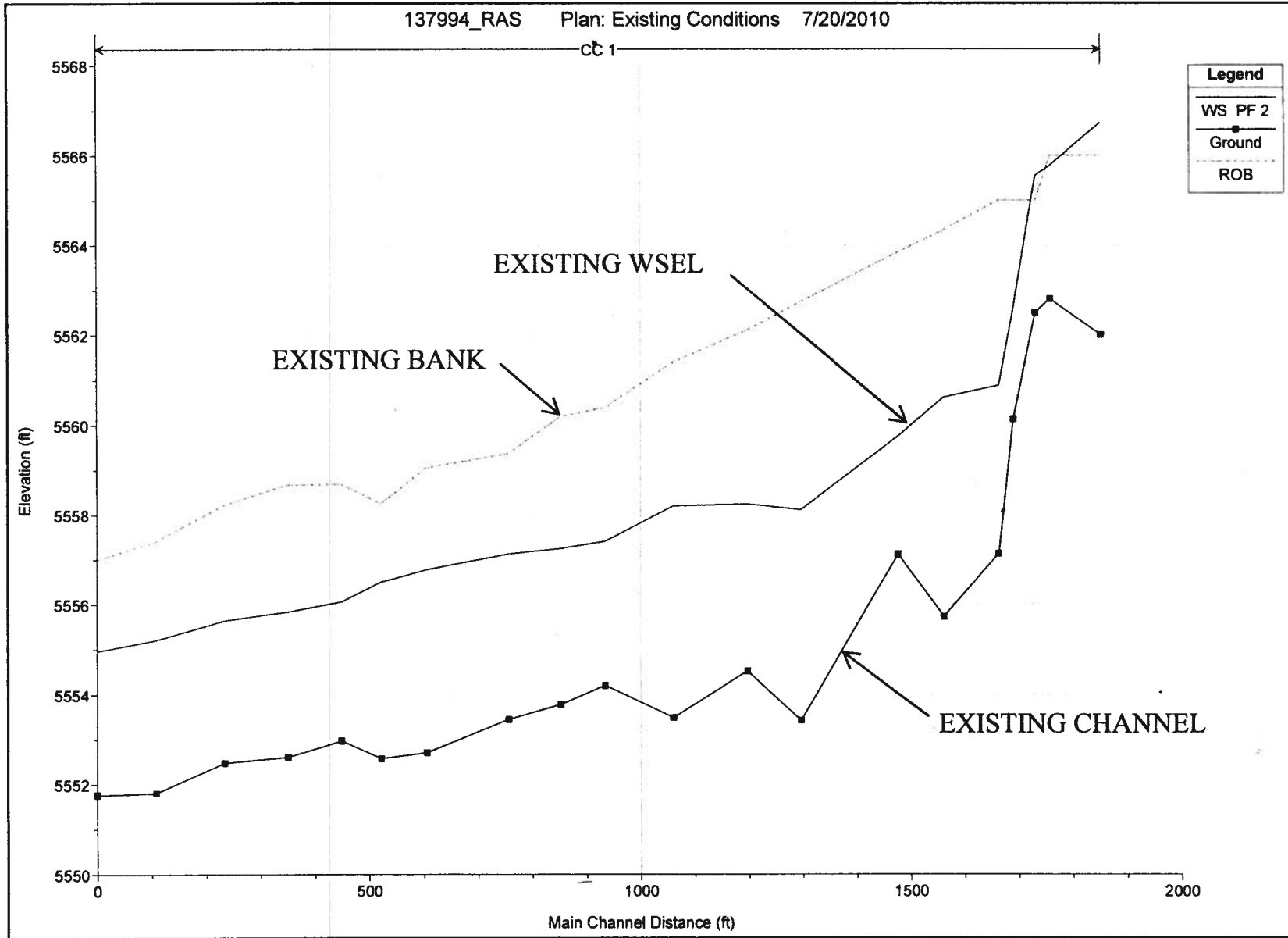


CHERRY CREEK BASIN WATER QUALITY AUTHORITY

CHERRY CREEK AT SHOP CREEK TRAIL
STREAM STABILIZATION PLAN

PLAN VIEW - OPTION 3

FIGURE 3



CHERRY CREEK BASIN WATER QUALITY AUTHORITY

CHERRY CREEK AT SHOP CREEK TRAIL
 STREAM STABILIZATION PLAN

EXISTING CHANNEL INVERT PROFILE

FIGURE
 4

12. MEMORANDUM ATTACHMENTS

ATTACHMENT A
PHOSPHORUS SAMPLING RESULTS

June 04, 2010

Report to:

Jennifer Winters
Brown & Caldwell
1697 Cole Blvd. Suite 200
Golden, CO 80401

Bill to:

Bill Ruzzo
Cherry Creek Basin Water Quality Authority
6641 W. Hamilton
Lakewood, CO 80227

Project ID: CC at Shop Crk Tr
ACZ Project ID: L82056

Jennifer Winters:

Enclosed are the analytical results for sample(s) submitted to ACZ Laboratories, Inc. (ACZ) on May 11, 2010. This project has been assigned to ACZ's project number, L82056. Please reference this number in all future inquiries.

All analyses were performed according to ACZ's Quality Assurance Plan. The enclosed results relate only to the samples received under L82056. Each section of this report has been reviewed and approved by the appropriate Laboratory Supervisor, or a qualified substitute.

Except as noted, the test results for the methods and parameters listed on ACZ's current NELAC certificate letter (#ACZ) meet all requirements of NELAC.

This report shall be used or copied only in its entirety. ACZ is not responsible for the consequences arising from the use of a partial report.

All samples and sub-samples associated with this project will be disposed of after July 04, 2010. If the samples are determined to be hazardous, additional charges apply for disposal (typically less than \$10/sample). If you would like the samples to be held longer than ACZ's stated policy or to be returned, please contact your Project Manager or Customer Service Representative for further details and associated costs. ACZ retains analytical reports for five years.

If you have any questions or other needs, please contact your Project Manager.



Tony Antalek has reviewed and approved this report.



Cherry Creek Basin Water Quality Authority

Project ID: CC at Shop Crk Tr
Sample ID: S1

ACZ Sample ID: **L82056-01**
Date Sampled: 05/10/10 13:45
Date Received: 05/11/10
Sample Matrix: Soil

Inorganic Prep

Parameter	EPA Method	Result	Qual	XQ	Units	MDL	PQL	Date	Analyst
Phosphorus, total	M365.1 - Auto Ascorbic Acid Digestion							05/28/10 13:08	mpb

Soil Analysis

Parameter	EPA Method	Result	Qual	XQ	Units	MDL	PQL	Date	Analyst
Solids, Percent	CLPSOW390, PART F, D-98	83.3		*	%	0.1	0.5	05/18/10 13:50	meg/br d

Texture by Hydrometer ASTM D 422 Hydrometer

Clay		21.3		*	%	0.1	0.5	05/26/10 0:00	bsu
Sand		48.8		*	%	0.1	0.5	05/26/10 0:00	bsu
Silt		30.0		*	%	0.1	0.5	05/26/10 0:00	bsu
Texture Classification		Loam		*				05/26/10 0:00	bsu

Soil Preparation

Parameter	EPA Method	Result	Qual	XQ	Units	MDL	PQL	Date	Analyst
Air Dry at 34 Degrees C	USDA No. 1, 1972							05/18/10 11:18	meg/br d
Sieve-2000 um (2.0mm)	ASA No.9, 15-4.2.2							05/25/10 15:00	meg

Wet Chemistry

Parameter	EPA Method	Result	Qual	XQ	Units	MDL	PQL	Date	Analyst
Phosphorus, total	M365.1 - Auto Ascorbic Acid (digest)	0.054		*	%	0.002	0.01	05/29/10 18:36	pjb

Cherry Creek Basin Water Quality Authority

Project ID: CC at Shop Crk Tr
Sample ID: S2

ACZ Sample ID: **L82056-02**
Date Sampled: 05/10/10 14:30
Date Received: 05/11/10
Sample Matrix: Soil

Inorganic Prep

Parameter	EPA Method	Result	Qual	XQ	Units	MDL	PQL	Date	Analyst
Phosphorus, total	M365.1 - Auto Ascorbic Acid Digestion							05/28/10 14:47	mpb

Soil Analysis

Parameter	EPA Method	Result	Qual	XQ	Units	MDL	PQL	Date	Analyst
Solids, Percent	CLPSOW390, PART F, D-98	76.2		*	%	0.1	0.5	05/18/10 15:45	meg/br d

Texture by Hydrometer ASTM D 422 Hydrometer

Clay		20.0		*	%	0.1	0.5	05/27/10 0:00	bsu
Sand		45.0		*	%	0.1	0.5	05/27/10 0:00	bsu
Silt		35.0		*	%	0.1	0.5	05/27/10 0:00	bsu
Texture Classification		Loam		*				05/27/10 0:00	bsu

Soil Preparation

Parameter	EPA Method	Result	Qual	XQ	Units	MDL	PQL	Date	Analyst
Air Dry at 34 Degrees C	USDA No. 1, 1972							05/18/10 11:23	meg/br d
Sieve-2000 um (2.0mm)	ASA No.9, 15-4.2.2							05/25/10 15:30	meg

Wet Chemistry

Parameter	EPA Method	Result	Qual	XQ	Units	MDL	PQL	Date	Analyst
Phosphorus, total	M365.1 - Auto Ascorbic Acid (digest)	0.059		*	%	0.002	0.01	05/29/10 18:37	pjb

Cherry Creek Basin Water Quality Authority

Project ID: CC at Shop Crk Tr
Sample ID: S3

ACZ Sample ID: **L82056-03**
Date Sampled: 05/10/10 14:45
Date Received: 05/11/10
Sample Matrix: Soil

Inorganic Prep

Parameter	EPA Method	Result	Qual	XQ	Units	MDL	PQL	Date	Analyst
Phosphorus, total	M365.1 - Auto Ascorbic Acid Digestion							05/28/10 16:25	mpb

Soil Analysis

Parameter	EPA Method	Result	Qual	XQ	Units	MDL	PQL	Date	Analyst
Solids, Percent	CLPSOW390, PART F, D-98	90.2		*	%	0.1	0.5	05/18/10 17:40	meg/br d

Texture by Hydrometer ASTM D 422 Hydrometer

Clay		15.0		*	%	0.1	0.5	05/27/10 0:00	bsu
Sand		68.8		*	%	0.1	0.5	05/27/10 0:00	bsu
Silt		16.3		*	%	0.1	0.5	05/27/10 0:00	bsu
Texture Classification		Sandy Loam		*				05/27/10 0:00	bsu

Soil Preparation

Parameter	EPA Method	Result	Qual	XQ	Units	MDL	PQL	Date	Analyst
Air Dry at 34 Degrees C	USDA No. 1, 1972							05/18/10 11:27	meg/br d
Sieve-2000 um (2.0mm)	ASA No.9, 15-4.2.2							05/25/10 16:00	meg

Wet Chemistry

Parameter	EPA Method	Result	Qual	XQ	Units	MDL	PQL	Date	Analyst
Phosphorus, total	M365.1 - Auto Ascorbic Acid (digest)	0.054		*	%	0.002	0.009	05/29/10 18:39	pjb

Report Header Explanations

Batch	A distinct set of samples analyzed at a specific time
Found	Value of the QC Type of interest
Limit	Upper limit for RPD, in %.
Lower	Lower Recovery Limit, in % (except for LCSS, mg/Kg)
MDL	Method Detection Limit. Same as Minimum Reporting Limit. Allows for instrument and annual fluctuations.
PCN/SCN	A number assigned to reagents/standards to trace to the manufacturer's certificate of analysis
PQL	Practical Quantitation Limit, typically 5 times the MDL.
QC	True Value of the Control Sample or the amount added to the Spike
Rec	Amount of the true value or spike added recovered, in % (except for LCSS, mg/Kg)
RPD	Relative Percent Difference, calculation used for Duplicate QC Types
Upper	Upper Recovery Limit, in % (except for LCSS, mg/Kg)
Sample	Value of the Sample of interest

QC Sample Types

AS	Analytical Spike (Post Digestion)	LCSWD	Laboratory Control Sample - Water Duplicate
ASD	Analytical Spike (Post Digestion) Duplicate	LFB	Laboratory Fortified Blank
CCB	Continuing Calibration Blank	LFM	Laboratory Fortified Matrix
CCV	Continuing Calibration Verification standard	LFMD	Laboratory Fortified Matrix Duplicate
DUP	Sample Duplicate	LRB	Laboratory Reagent Blank
ICB	Initial Calibration Blank	MS	Matrix Spike
ICV	Initial Calibration Verification standard	MSD	Matrix Spike Duplicate
ICSAB	Inter-element Correction Standard - A plus B solutions	PBS	Prep Blank - Soil
LCSS	Laboratory Control Sample - Soil	PBW	Prep Blank - Water
LCSSD	Laboratory Control Sample - Soil Duplicate	PQV	Practical Quantitation Verification standard
LCSW	Laboratory Control Sample - Water	SDL	Serial Dilution

QC Sample Type Explanations

Blanks	Verifies that there is no or minimal contamination in the prep method or calibration procedure.
Control Samples	Verifies the accuracy of the method, including the prep procedure.
Duplicates	Verifies the precision of the instrument and/or method.
Spikes/Fortified Matrix	Determines sample matrix interferences, if any.
Standard	Verifies the validity of the calibration.

ACZ Qualifiers (Qual)

B	Analyte concentration detected at a value between MDL and PQL. The associated value is an estimated quantity.
H	Analysis exceeded method hold time. pH is a field test with an immediate hold time.
U	The material was analyzed for, but was not detected above the level of the associated value. The associated value is either the sample quantitation limit or the sample detection limit.

Method References

- (1) EPA 600/4-83-020. Methods for Chemical Analysis of Water and Wastes, March 1983.
- (2) EPA 600/R-93-100. Methods for the Determination of Inorganic Substances in Environmental Samples, August 1993.
- (3) EPA 600/R-94-111. Methods for the Determination of Metals in Environmental Samples - Supplement I, May 1994.
- (5) EPA SW-846. Test Methods for Evaluating Solid Waste, Third Edition with Update III, December 1996.
- (6) Standard Methods for the Examination of Water and Wastewater, 19th edition, 1995 & 20th edition (1998).

Comments

- (1) QC results calculated from raw data. Results may vary slightly if the rounded values are used in the calculations.
- (2) Soil, Sludge, and Plant matrices for Inorganic analyses are reported on a dry weight basis.
- (3) Animal matrices for Inorganic analyses are reported on an "as received" basis.
- (4) An asterisk in the "XQ" column indicates there is an extended qualifier and/or certification qualifier associated with the result.

For a complete list of ACZ's Extended Qualifiers, please click:

<http://www.acz.com/public/extquallist.pdf>

Cherry Creek Basin Water Quality Authority

ACZ Project ID: **L82056**

ACZ ID	WORKNUM	PARAMETER	METHOD	QUAL	DESCRIPTION
--------	---------	-----------	--------	------	-------------

No extended qualifiers associated with this analysis

Soil Analysis

The following parameters are not offered for certification or are not covered by NELAC certificate #ACZ.

Clay	ASTM D 422 Hydrometer
Sand	ASTM D 422 Hydrometer
Silt	ASTM D 422 Hydrometer
Solids, Percent	CLPSOW390, PART F, D-98
Texture Classification	ASTM D 422 Hydrometer

Wet Chemistry

The following parameters are not offered for certification or are not covered by NELAC certificate #ACZ.

Phosphorus, total	M365.1 - Auto Ascorbic Acid (digest)
-------------------	--------------------------------------

Cherry Creek Basin Water Quality Authority
 CC at Shop Crk Tr

ACZ Project ID: L82056
 Date Received: 05/11/2010 10:16
 Received By: gac
 Date Printed: 5/11/2010

Receipt Verification

	YES	NO	NA
1) Does this project require special handling procedures such as CLP protocol?			X
2) Are the custody seals on the cooler intact?			X
3) Are the custody seals on the sample containers intact?			X
4) Is there a Chain of Custody or other directive shipping papers present?	X		
5) Is the Chain of Custody complete?	X		
6) Is the Chain of Custody in agreement with the samples received?	X		
7) Is there enough sample for all requested analyses?	X		
8) Are all samples within holding times for requested analyses?	X		
9) Were all sample containers received intact?	X		
10) Are the temperature blanks present?			X
11) Are the trip blanks (VOA and/or Cyanide) present?			X
12) Are samples requiring no headspace, headspace free?			X
13) Do the samples that require a Foreign Soils Permit have one?			X

Exceptions: If you answered no to any of the above questions, please describe

N/A

Contact (For any discrepancies, the client must be contacted)

N/A

Shipping Containers

Cooler Id	Temp (°C)	Rad (µR/hr)
NA10793	4.1	10

Client must contact ACZ Project Manager if analysis should not proceed for samples received outside of thermal preservation acceptance criteria.

Notes

Cherry Creek Basin Water Quality Authority
 CC at Shop Crk Tr

ACZ Project ID: L82056
 Date Received: 05/11/2010 10:16
 Received By: gac
 Date Printed: 5/11/2010

Sample Container Preservation

SAMPLE	CLIENT ID	R < 2	G < 2	BK < 2	Y < 2	YG < 2	B < 2	O < 2	T > 12	N/A	RAD	ID
L82056-01	S1									X		<input type="checkbox"/>
L82056-02	S2									X		<input type="checkbox"/>
L82056-03	S3									X		<input type="checkbox"/>

Sample Container Preservation Legend

Abbreviation	Description	Container Type	Preservative/Limits
R	Raw/Nitric	RED	pH must be < 2
B	Filtered/Sulfuric	BLUE	pH must be < 2
BK	Filtered/Nitric	BLACK	pH must be < 2
G	Filtered/Nitric	GREEN	pH must be < 2
O	Raw/Sulfuric	ORANGE	pH must be < 2
P	Raw/NaOH	PURPLE	pH must be > 12 *
T	Raw/NaOH Zinc Acetate	TAN	pH must be > 12
Y	Raw/Sulfuric	YELLOW	pH must be < 2
YG	Raw/Sulfuric	YELLOW GLASS	pH must be < 2
N/A	No preservative needed	Not applicable	
RAD	Gamma/Beta dose rate	Not applicable	must be < 250 µR/hr

* pH check performed by analyst prior to sample preparation

Sample IDs Reviewed By: gac



Laboratories, Inc. *CE2056*

CHAIN of CUSTODY

2773 Downhill Drive Steamboat Springs, CO 80487 (800) 334-5493

Report to:

Name: <i>Jennifer Winters</i>	Address: <i>1697 Cole Blvd., Ste. 200</i>
Company: <i>Brown & Caldwell</i>	<i>Golden, CO 80401</i>
E-mail: <i>jwinters@brownca.com</i>	Telephone: <i>303.239.5400</i>

Copy of Report to:

Name:	E-mail:
Company:	Telephone:

Invoice to:

Name: <i>Bill Ruzzo</i>	Address: <i>6641 W. Hamilton</i>
Company: <i>Cherry Creek Basin Water Quality Auth.</i>	<i>Lakewood, CO 80227</i>
E-mail: <i>bill.ruzzo@comcast.net</i>	Telephone: <i>303.985.1091</i>

If sample(s) received past holding time (HT), or if insufficient HT remains to complete analysis before expiration, shall ACZ proceed with requested short HT analyses? YES NO

If "NO" then ACZ will contact client for further instruction. If neither "YES" nor "NO" is indicated, ACZ will proceed with the requested analyses, even if HT is expired, and data will be qualified.

Are samples for SDWA Compliance Monitoring? Yes No

If yes, please include state forms. Results will be reported to PQL for Colorado.

Sampler's Name: *Jennifer Winters* Sampler's site information State *CO* Zip code _____ Time Zone _____

PROJECT INFORMATION

ANALYSIS REQUIRED (attach list or use quote number)

Quote #:	Project/PO #:	Reporting state for compliance testing:	Are any samples NRC licensable material? Yes (No)	SAMPLE IDENTIFICATION	DATE: TIME	Matrix	# of Containers	Total Phosphorus	Particle Size						
<i>_____</i>	<i>Cherry Creek @ Shop Creek Trail</i>		<i>(No)</i>	<i>S1</i>	<i>5/10/10 1:45 pm</i>	<i>SO</i>	<i>1</i>	<i>✓</i>	<i>✓</i>						
				<i>S2</i>	<i>5/10/10 2:30 pm</i>	<i>SO</i>	<i>1</i>	<i>✓</i>	<i>✓</i>						
				<i>S3</i>	<i>5/10/10 2:45 pm</i>	<i>SO</i>	<i>1</i>	<i>✓</i>	<i>✓</i>						
					<i>SW</i>										

Matrix SW (Surface Water) · GW (Ground Water) · WW (Waste Water) · DW (Drinking Water) · SL (Sludge) · SO (Soil) · OL (Oil) · Other (Specify)

REMARKS

ACZ contact — Tony Antalek
Account # CCB

Please refer to ACZ's terms & conditions located on the reverse side of this COC.

RELINQUISHED BY:	DATE: TIME	RECEIVED BY:	DATE: TIME
<i>Jennifer Winters</i>	<i>5/10/10 5:00 pm</i>	<i>RedEx</i>	<i>5/10/10 5:00 pm</i>
			<i>5-11-10 1000</i>

Location _____ Date _____

Project / Client _____

Location CC @ Shop Creek Tr. Date 5/10/10

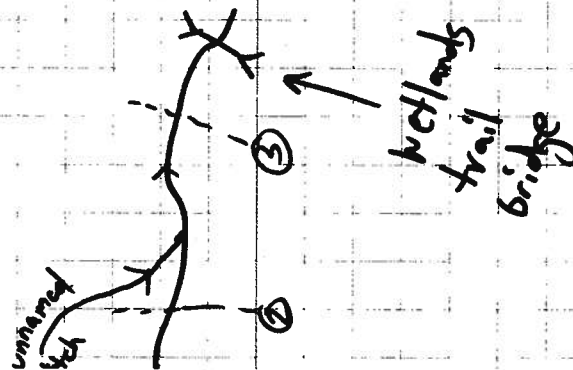
15

Project / Client CCBWQA - Phosphorus Sampling
JWinters

1:30 pm - Arrived @ site. Sunny. Breezy.
~ 65° F.

1:35 pm - Photo 1 → Aurora water line
2 → rip-rap area

1:40 pm - Began Sampling
Sample Sites



Location CC @ Shop Creek Trail Date 5/10/10
Project / Client CCBWQA - Phosphorus Sampling
J. Winters

15 pm Sample 1; ~60 ft $\frac{1}{2}$ s Avorn rip-rap

Note: All samples taken as composites of 2 samples taken on opposite stream banks. Samples consisted of at least 2 soil types - determined by visual examination of soils.

20 pm photo 3 - right bank sample site
photo 4 - left " " "

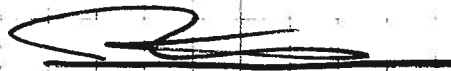
30 pm Sample 2; ~80 ft $\frac{1}{2}$ s of unnamed ditch

~~40~~ 45 pm Sample 3; ~ just $\frac{1}{2}$ s of wetlands trail bridge

17
Location CC @ Shop Creek Trail Date 5/10/10
Project / Client CCBWQA - Phosphorus Sampling
J. Winters

Note: Flow was too high to cross creek by wading. Had to walk back around to take 2nd sample @ site 2.

4:00 pm Departed CC Reservoir. Next stop FedEx to ship samples to ACZ labs. Then return to BC.


Jennifer Winters

Photos taken during 5/10/10 Phosphorus Sampling
J.Winters

Photo	Description
4113	Aurora Water line riprap area
4114	Aurora Water line riprap area
4115	Sample Site 1
4116	Sample Site 1
4117	Sample Site 3
4118	Sample Site 3
4119	Sample Site 2
4120	Sample Site 2



Photo 4113



Photo 4114



Photo 4115



Photo 4116



Photo 4117



Photo 4118

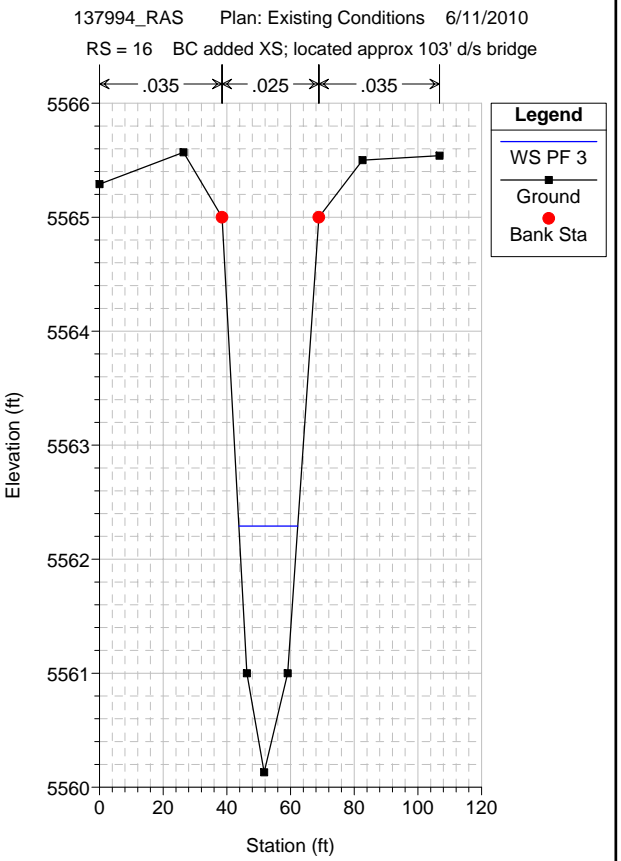
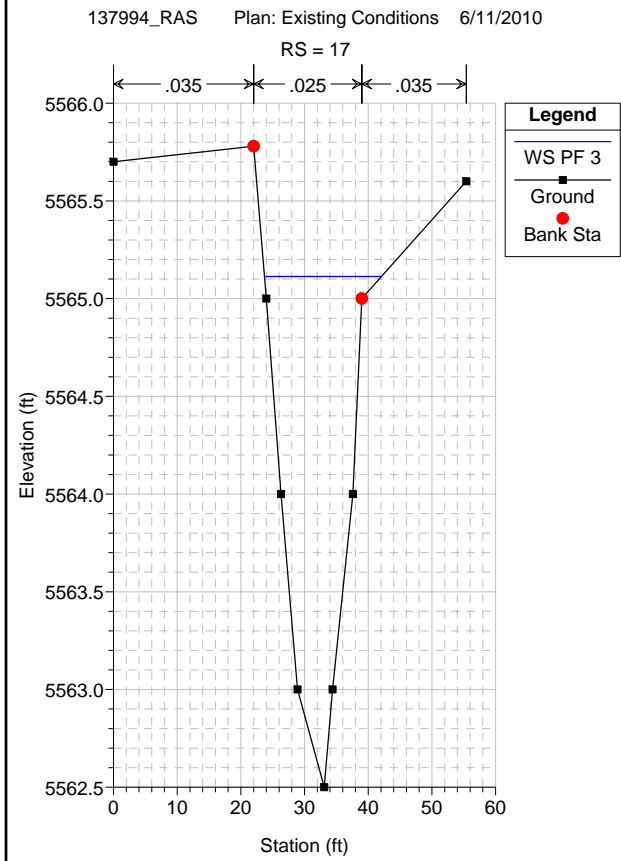
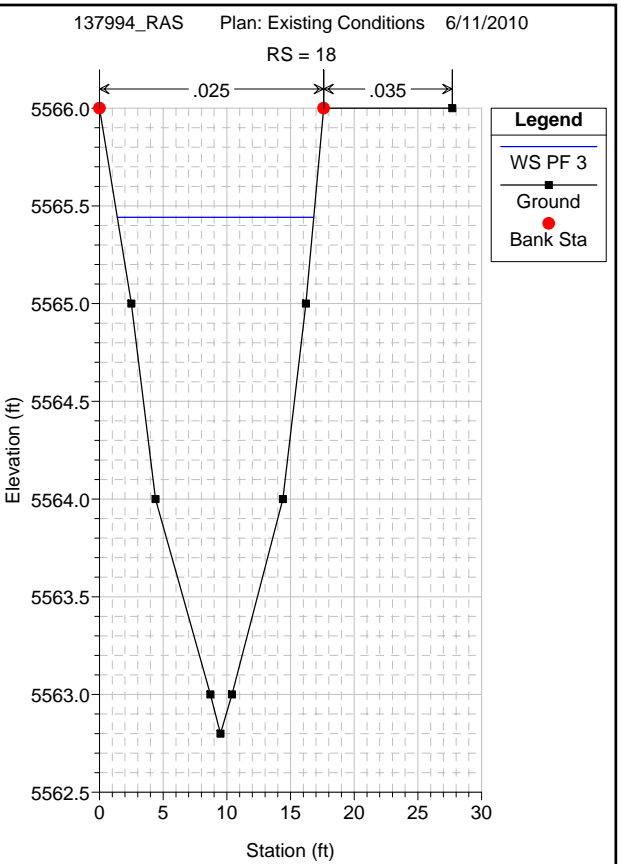
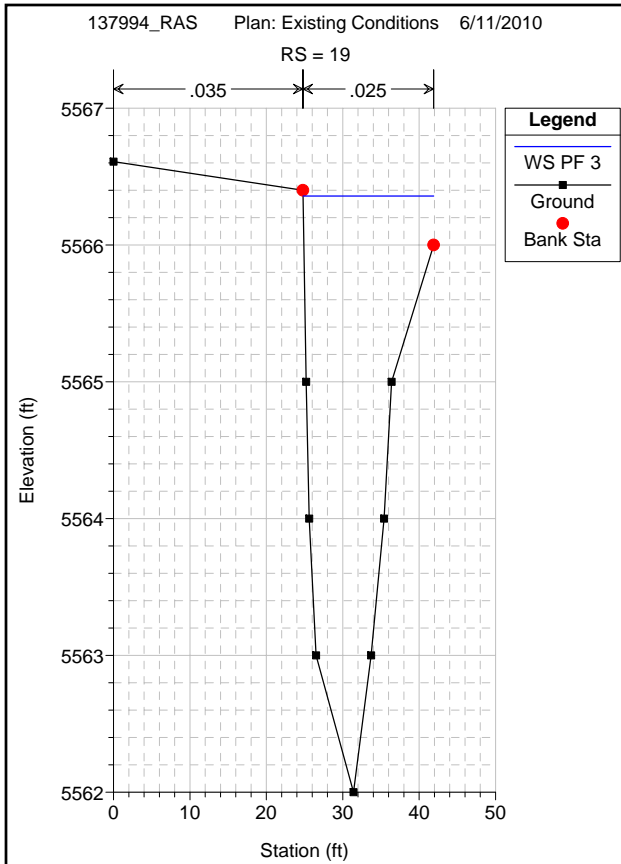


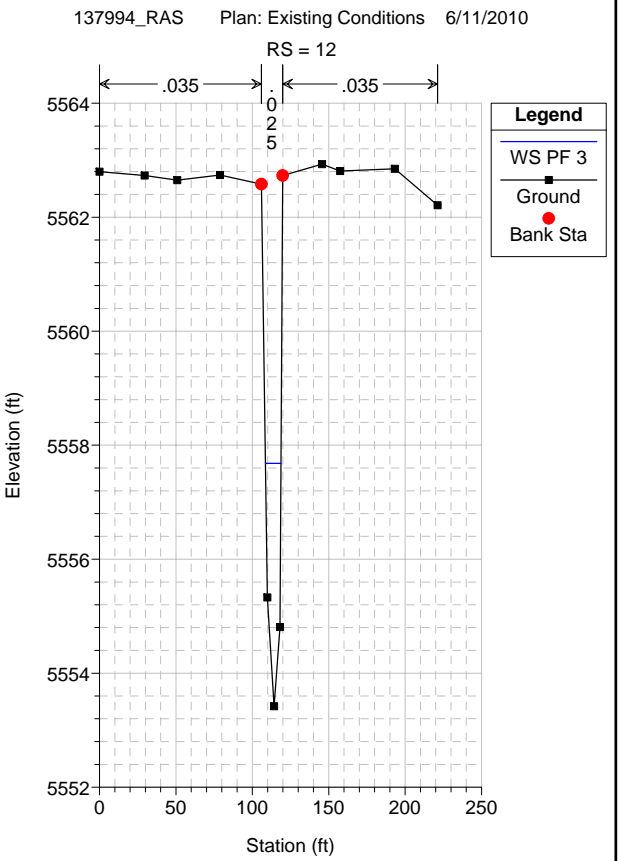
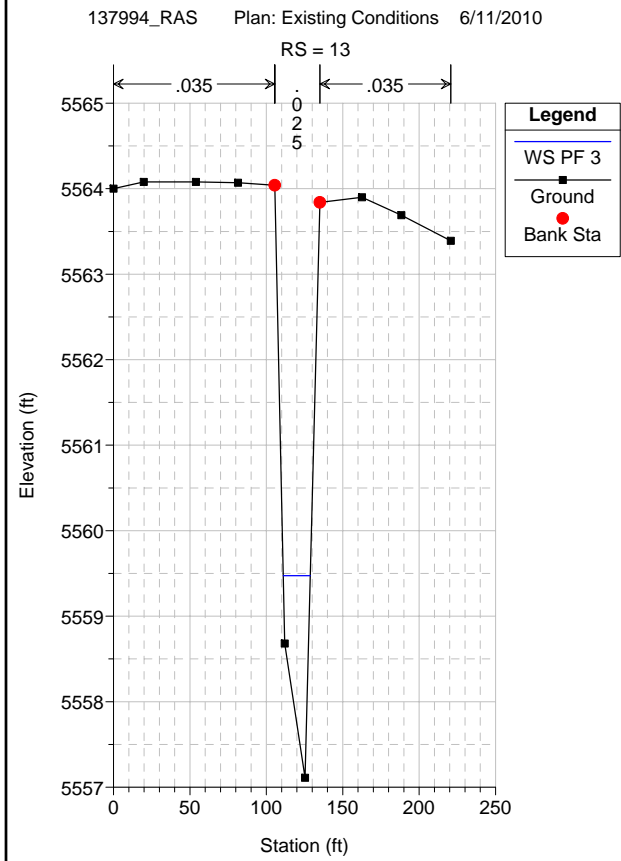
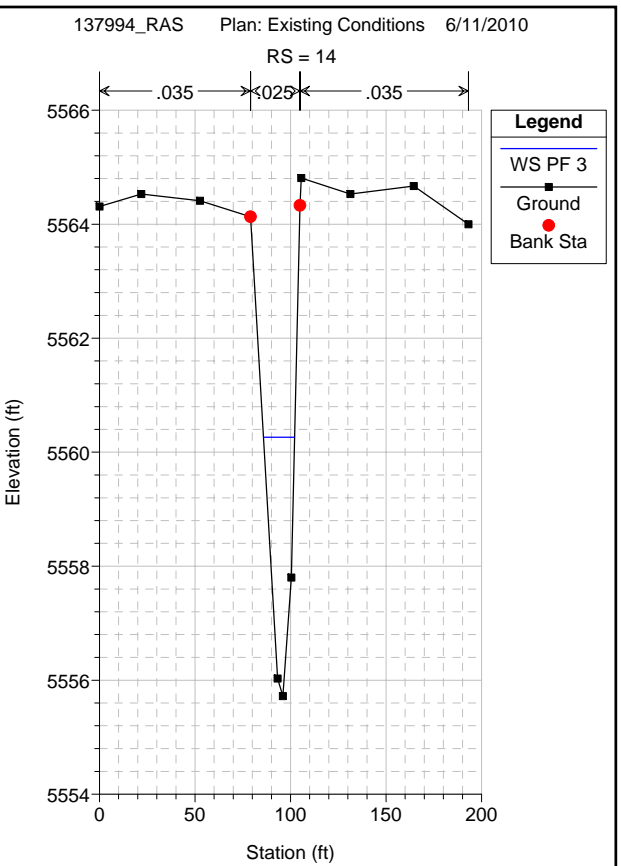
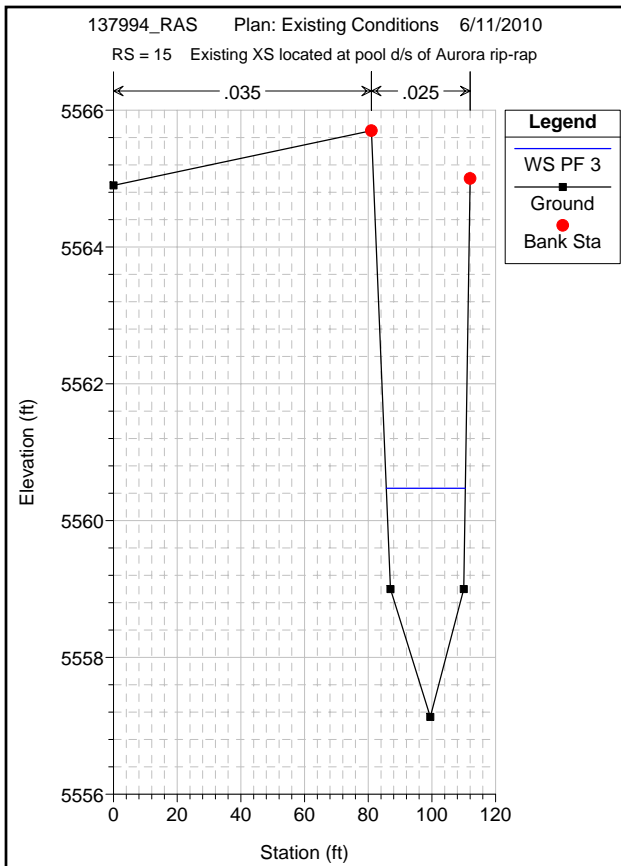
Photo 4119

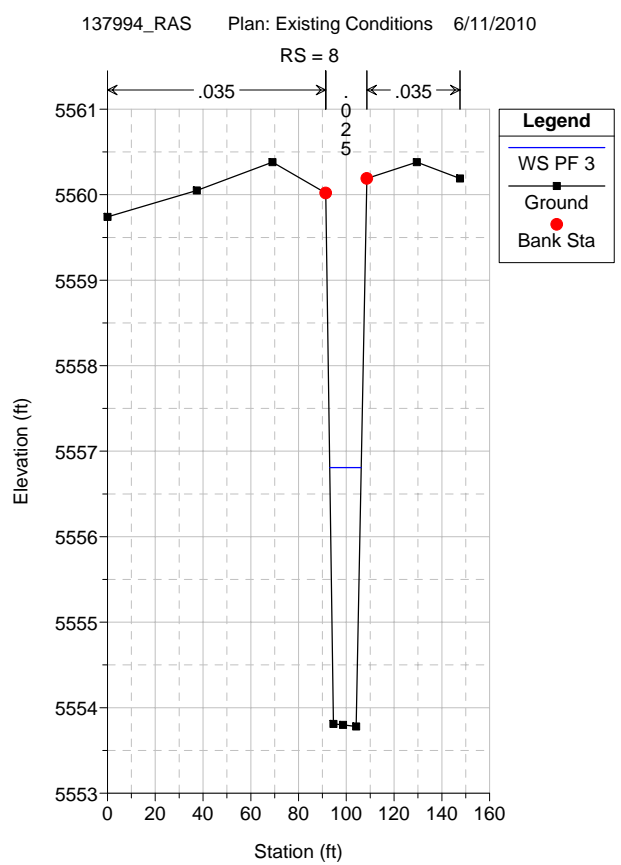
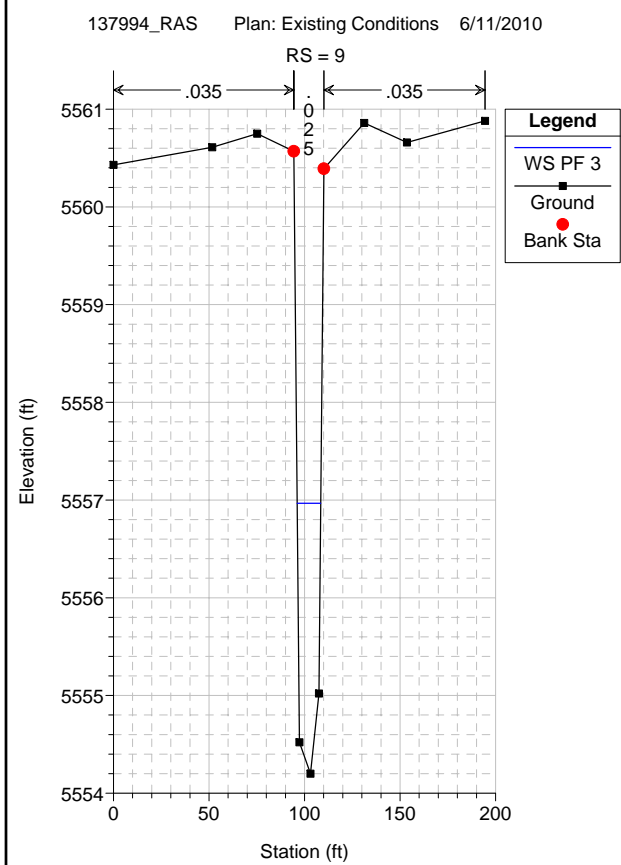
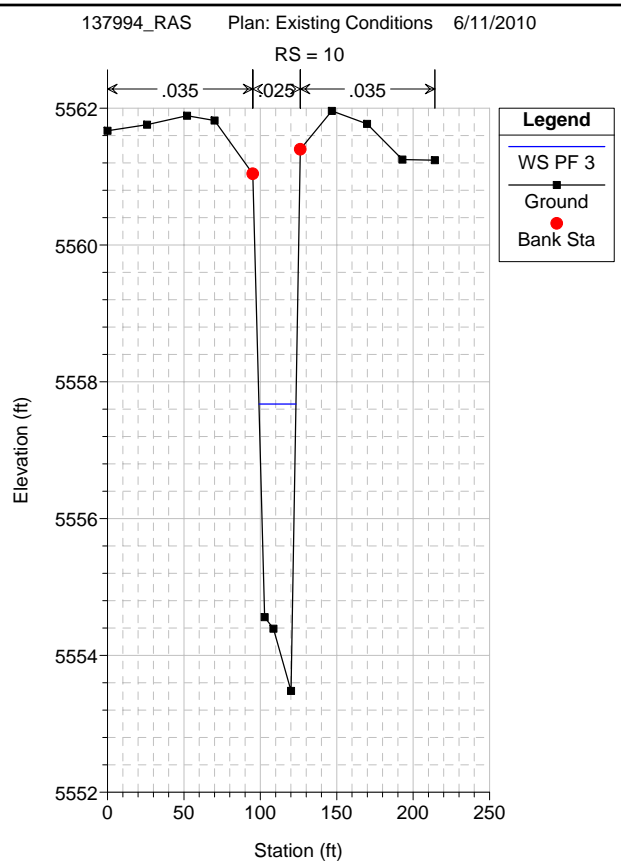
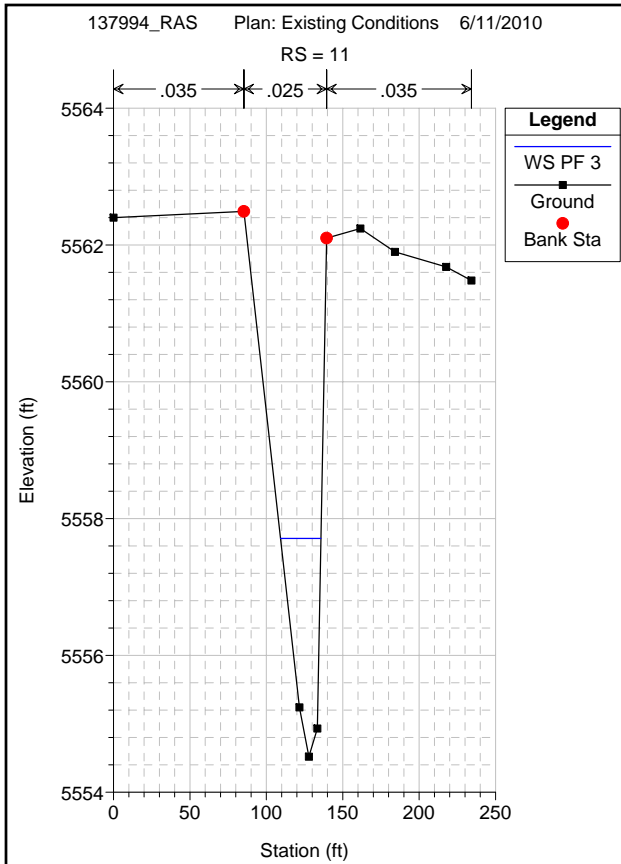


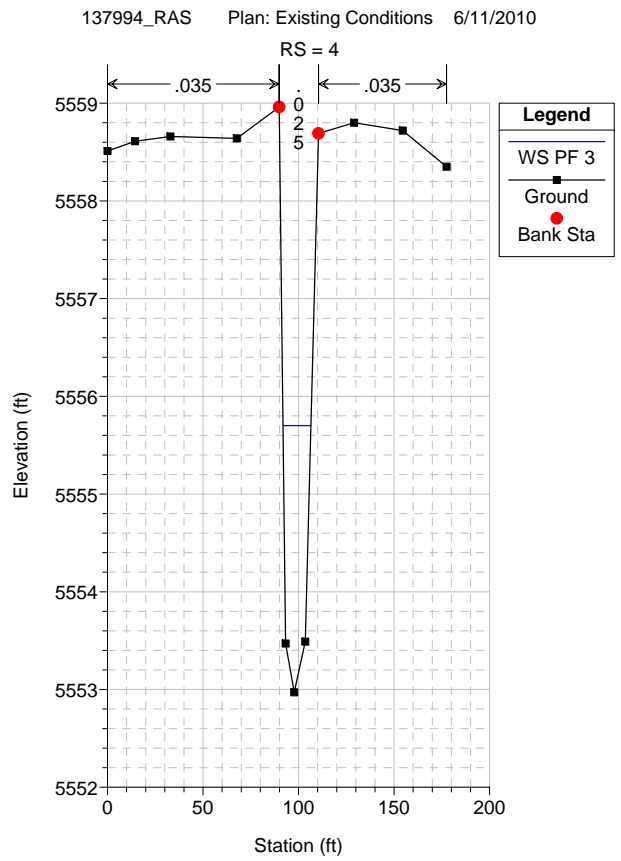
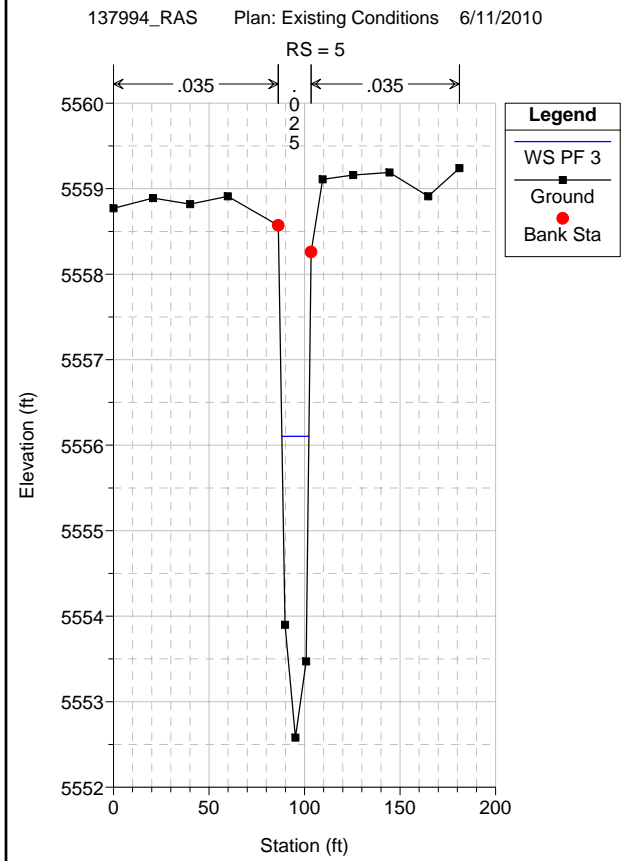
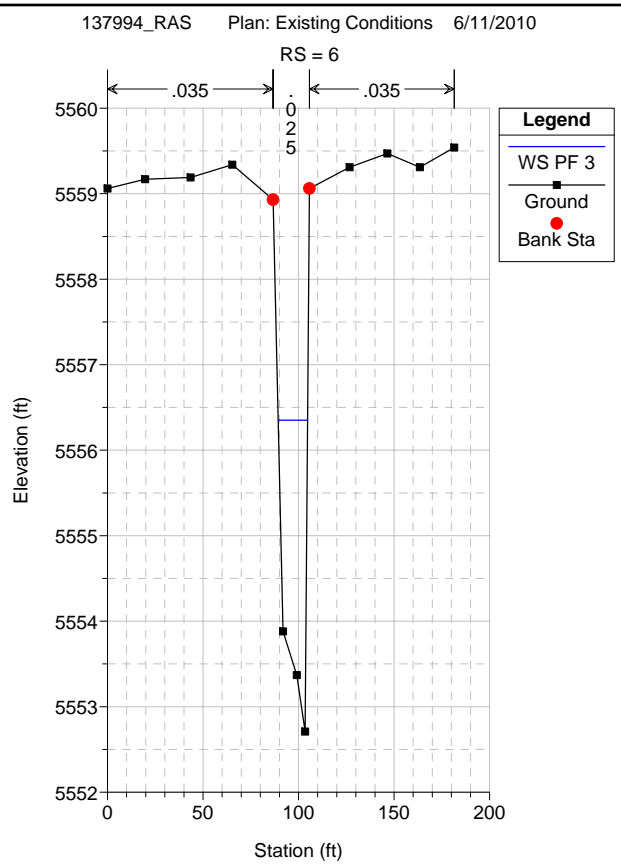
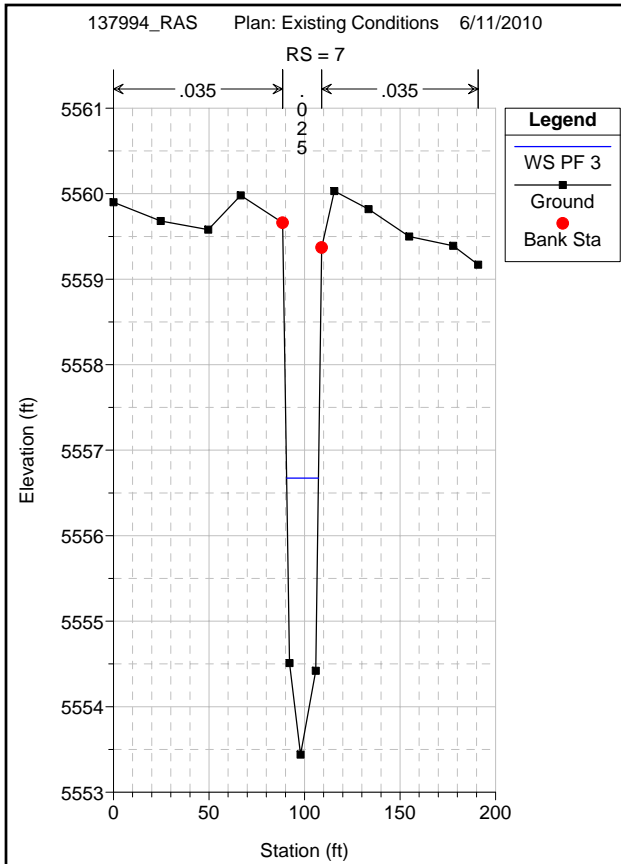
Photo 4120

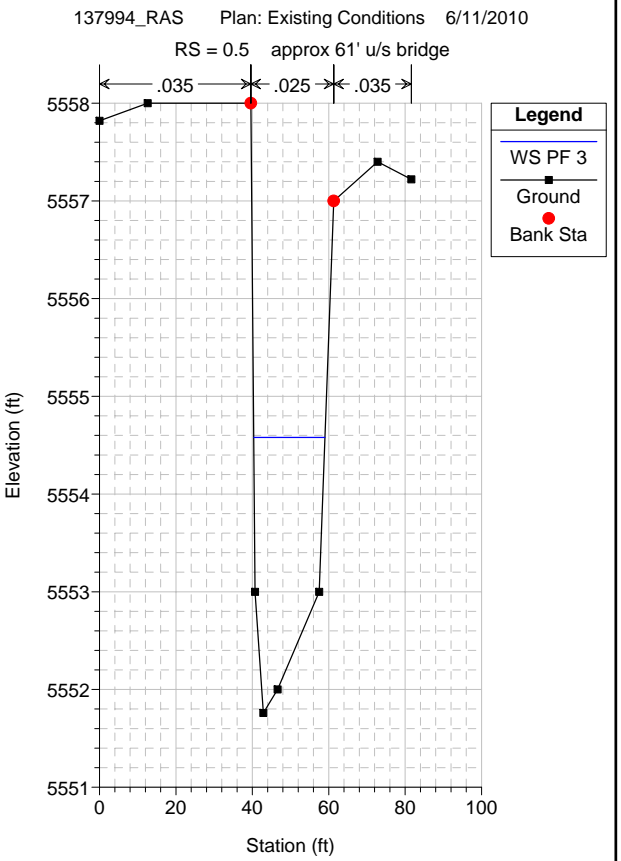
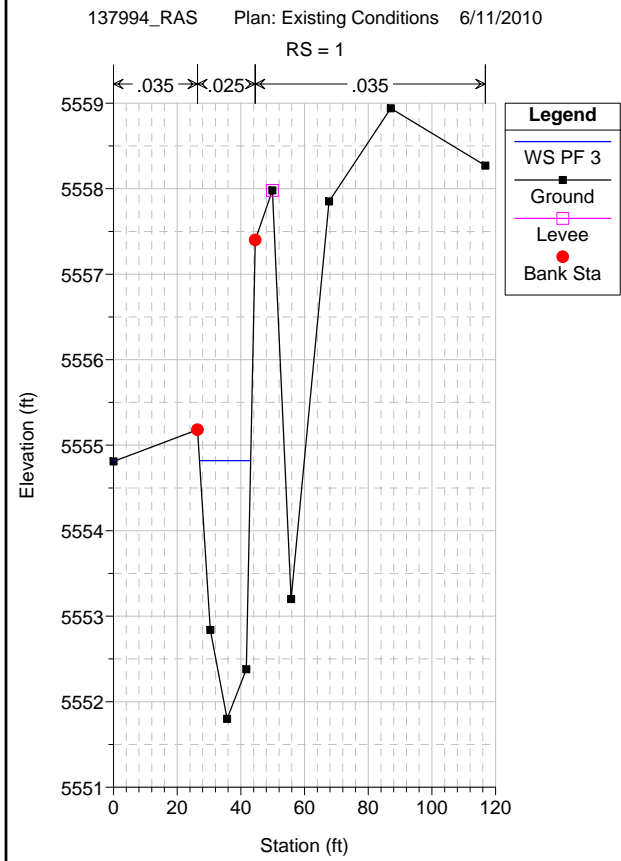
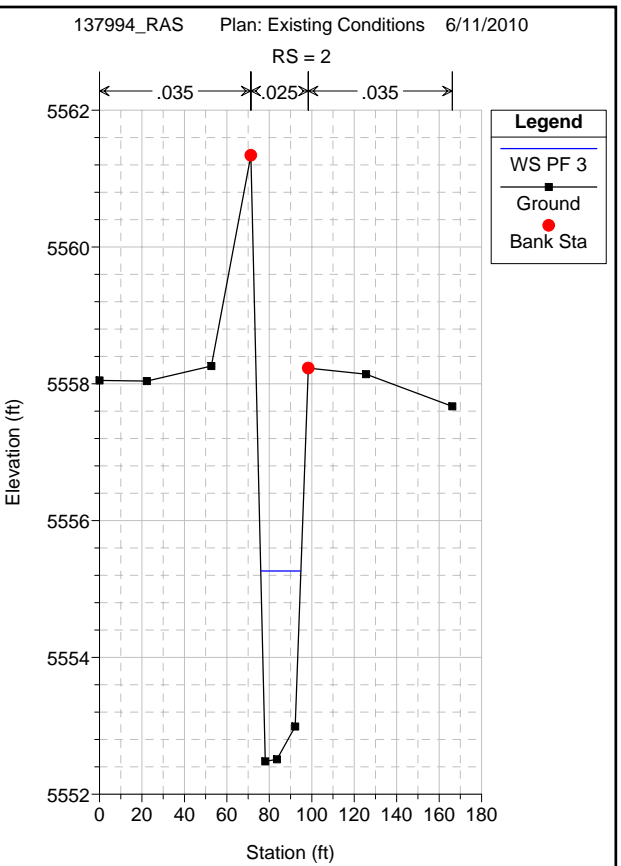
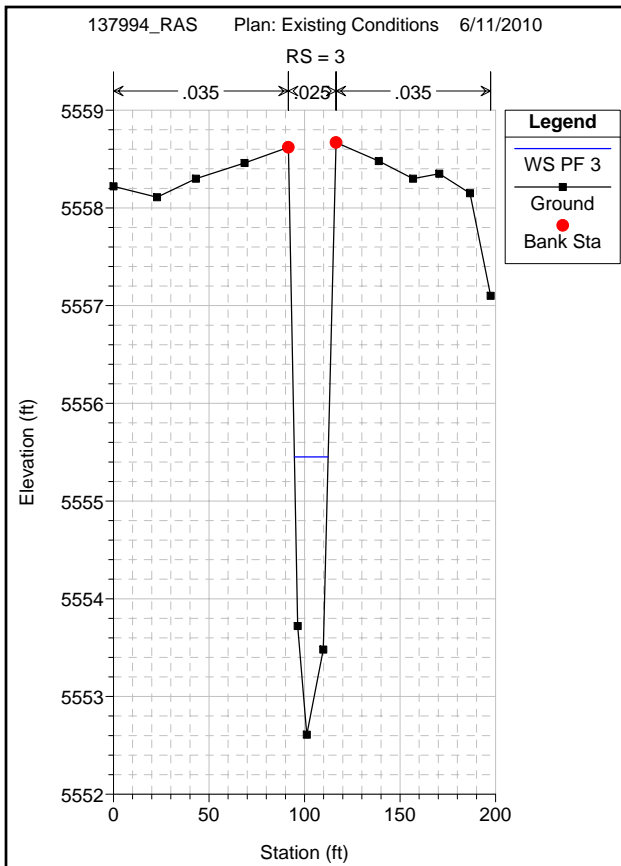
ATTACHMENT B
CROSS SECTIONS OF EXISTING STREAM CHANNEL











ATTACHMENT C
GEOTECHNICAL ANALYSIS REPORT



GEOTECHNICAL STUDY

Cherry Creek at Shop Creek Trail
Cherry Creek State Park
Arapahoe County, Colorado

Project No. D09.163.A

Report Prepared for:

Ms. Dorothy Eisenbraun, P.E.
Brown and Caldwell
1697 Cole Boulevard, Suite 200
Golden, Colorado 80401

Prepared by:



Darin R. Duran, P.E.
Principal, Geotechnical Engineering Manager

December 17, 2009

TABLE OF CONTENTS

	<u>Page</u>
PURPOSE	1
PROPOSED CONSTRUCTION	1
SITE HISTORY AND CONDITIONS	1
INVESTIGATIONS.....	1
SUBSURFACE CONDITIONS	2
LABORATORY TESTING	2
GEOTECHNICAL CONSIDERATIONS.....	2
FOUNDATION RECOMMENDATIONS	3
LATERAL EARTH PRESSURES	4
LIMITATIONS	4
VICINITY MAP.....	FIGURE 1
SITE PLAN	FIGURE 2
LOG OF TEST HOLE (INCLUDES KEY TO SYMBOLS).....	FIGURE 3
GRADATION PLOTS.....	FIGURES 4 THROUGH 6

PURPOSE

This report presents results of a geotechnical study for the proposed reclamation of Cherry Creek from the Wetlands Trail to Shop Creek Trail in Cherry Creek State Park, Arapahoe County, Colorado. The study was made to assist in determining design criteria for bridge foundation systems, drop structures, and to present other pertinent geotechnical issues. Factual data gathered during the field and laboratory work is summarized in Tables 1 through 3 and Figures 1 through 6, attached. Our opinions and recommendations presented in this report are based on the data generated during this field investigation, laboratory testing, and our experience with similar-type projects.

PROPOSED CONSTRUCTION

The proposed construction consists of bridge over Cherry Creek on Shop Creek Trail and drop structures along Cherry Creek between the Wetlands Trail and Shop Creek Trail in order to reclaim and stabilize the stream bed. The bridge will support predominantly pedestrian traffic but maintenance vehicles will also use the bridge. The foundation system for the bridge will likely consist of a deep foundation system such as driven H-piles or drilled piers. Drop structures will likely consist of driven sheet pile walls or cast-in-place concrete walls.

SITE HISTORY AND CONDITIONS

Erosion along Cherry Creek occurred downstream of the Shop Creek Trail bridge sometime prior to 2008. The erosion consisted of head cutting that was progressing upstream. After storm events in 2009, the erosion had progressed upstream eventually causing collapse of the Shop Creek Trail bridge and exposing two City of Aurora raw water lines. The site is located in Cherry Creek State Park. A vicinity map is shown in Figure 1. The site is generally level but does slope gently to the northwest towards the reservoir. The Shop Creek Trail is about 10 feet wide and is unpaved. Cherry Creek crosses the site from southeast to northwest. The site vegetation consists of heavy growth of cottonwood trees, shrubs and grasses. There are no bedrock outcrops on site.

INVESTIGATIONS

Due to site access limitations only one test hole could be completed for this study. The location of the test hole is indicated in Figure 2. The test hole was advanced using a 6-inch diameter hollow stem auger powered by a CME-55 drilling rig. At frequent intervals, samples of the subsoil were taken using a California sampler, which is driven into the soil by dropping a

140-pound hammer through a free fall of 30 inches. The California sampler is a 2.5-inch outside diameter by 2-inch inside diameter device. The procedure to drive the California sampler into the soil and to record the number of blows required to drive the sampler into the soil is known as a penetration test. The number of blows required for the sampler to penetrate 12 inches gives an indication of the consistency or relative density of the soils encountered. Results of the penetration tests and locations of sampling are presented on the Logs of Test Hole, Figure 3.

SUBSURFACE CONDITIONS

Our test hole indicates the subsoil consists of sands with clayey sand and sandy clay lenses. The sands are described as clean, medium dense to dense, poorly graded and fine to medium grained above a depth of 25 feet and well graded below a depth of 25 feet, moist to wet, light brown to brown. The clayey sand and sandy clay was encountered in the upper 5 feet of the test hole and as 6 to 12 inches lenses in the clean sands. The clayey sand is medium dense to dense and the sandy clay is very stiff to hard, medium plasticity. The upper 3 to 5 feet contains cobbles up to 6-inches in diameter. Bedrock was not encountered to full depth explored of 51 feet. Groundwater was measured at a depth of 9 feet at the time of drilling. A more complete description of the subsoil and groundwater is shown in Figure 3.

These observations represent conditions at the time of field exploration and may not be indicative of other times or other locations. Groundwater can be expected to fluctuate with various seasonal and weather conditions.

LABORATORY TESTING

Samples were returned to the laboratory where they were visually classified and appropriate testing assigned to specific samples to evaluate pertinent engineering properties. The laboratory tests included three gradation analysis tests, which were conducted to evaluate grain-size distribution of selected samples. These results are presented in Figures 4 through 6.

GEOTECHNICAL CONSIDERATIONS

From our conversations with Brown and Caldwell, a deep foundation system is preferred for the bridge abutments. Due to the shallow groundwater depth and the existence of clean sands in the subsurface, a drilled pier foundation will encounter flowing sands and will be difficult to construct. We recommend a driven H-pile foundation system. These same

conditions will also create difficulty in constructing cast-in-place concrete drop structures. We recommend driven sheet piles.

Both the driven H-piles and sheet piles may encounter cobbles up to 6 inches in diameter in the upper 5 feet. These cobbles may be from previous construction activities on-site. If difficulty is encountered during driving of the piles in this material, removing the material during construction may be an alternative.

FOUNDATION RECOMMENDATIONS

Steel H-piles driven in the subsurface materials will likely not encounter bedrock or refusal conditions to a depth of 60 feet. The piles should be designed under friction conditions and no end bearing using the lateral load resistance indicated in Table 1. A working stress of 12 kips per square inch (ksi) is recommended for design.

Groups of piles required to support concentrated loads will require appropriate reductions of the axial and lateral capacities on the effective envelope of the pile group. Spacing piles at a minimum distance of at least three diameters center to center can avoid this reduction. Piles spaced less than three diameters center to center should be evaluated on an individual basis to determine appropriate reductions to axial and lateral capacities.

The contractor should select a driving hammer and cushion combination that is capable of installing the selected piling without overstressing the pile material. We recommend that the capacity of at least one pile be evaluated during pile installation using the Pile Driving Analyzer (PDA). The pile hammer should be operated at the manufacturer’s recommended stroke when measuring penetration resistance. Each pile should be observed and checked for buckling, crimping, and alignment in addition to recording penetration resistance, depth of embedment, and general pile driving operations.

TABLE 1
Lateral Load Design Criteria

Material	Subgrade Modulus (pci)	Φ(degrees)	Cohesion (psf)	ε ₅₀	Effective Unit Weigh (pcf)
Sand and Clay	60	30	0	N/A	70

LATERAL EARTH PRESSURES

Lateral pressures on walls depend upon the type of wall, hydrostatic pressure behind the wall, type of backfill material, and allowable wall movements. Where anticipated wall movements are less than approximately 0.5 percent of the wall height or wall movement is constrained, lateral earth pressures should be estimated for an "at rest" condition. Where anticipated wall movements are greater than 0.5 percent of the wall height, lateral earth pressures should be estimated for an "active" condition. Recommended design lateral earth pressures are shown in Tables 2 and 3. If these criteria cannot be met then we should be contacted for additional criteria. We recommend that a coefficient of sliding resistance between the sheet pile and soils of 0.4 be assumed in the analysis.

TABLE 2

Lateral Earth Pressure, No Hydrostatic Pressure

Parameter	Value (pcf)
At Rest	55
Active	40
Passive	250

TABLE 3

Lateral Earth Pressure, Submerged

Parameter	Value (pcf)
At Rest	90
Active	80
Passive	200

LIMITATIONS

The professional judgments expressed in this report meet the standard care of our profession. The test hole drilled for this study was located to obtain a reasonably accurate picture of underground conditions for design purposes. Variations frequently occur from these conditions, which are not indicated by the test hole. These variations are sometimes sufficient to necessitate modifications in the design. If unexpected conditions are observed during construction, we should be notified to review our recommendations.



SCALE IN FEET



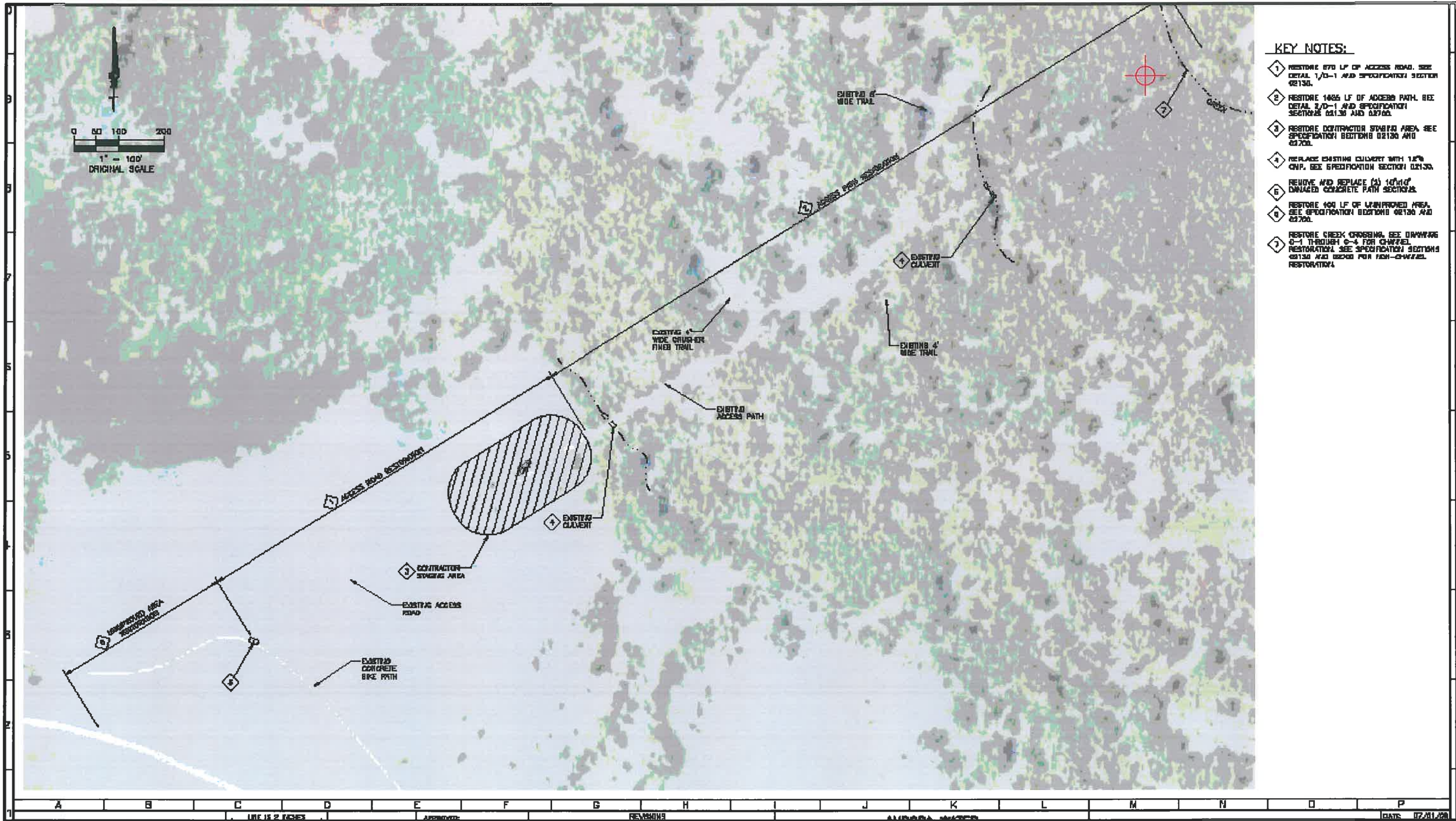
Explanation



Vicinity of
Figure 2

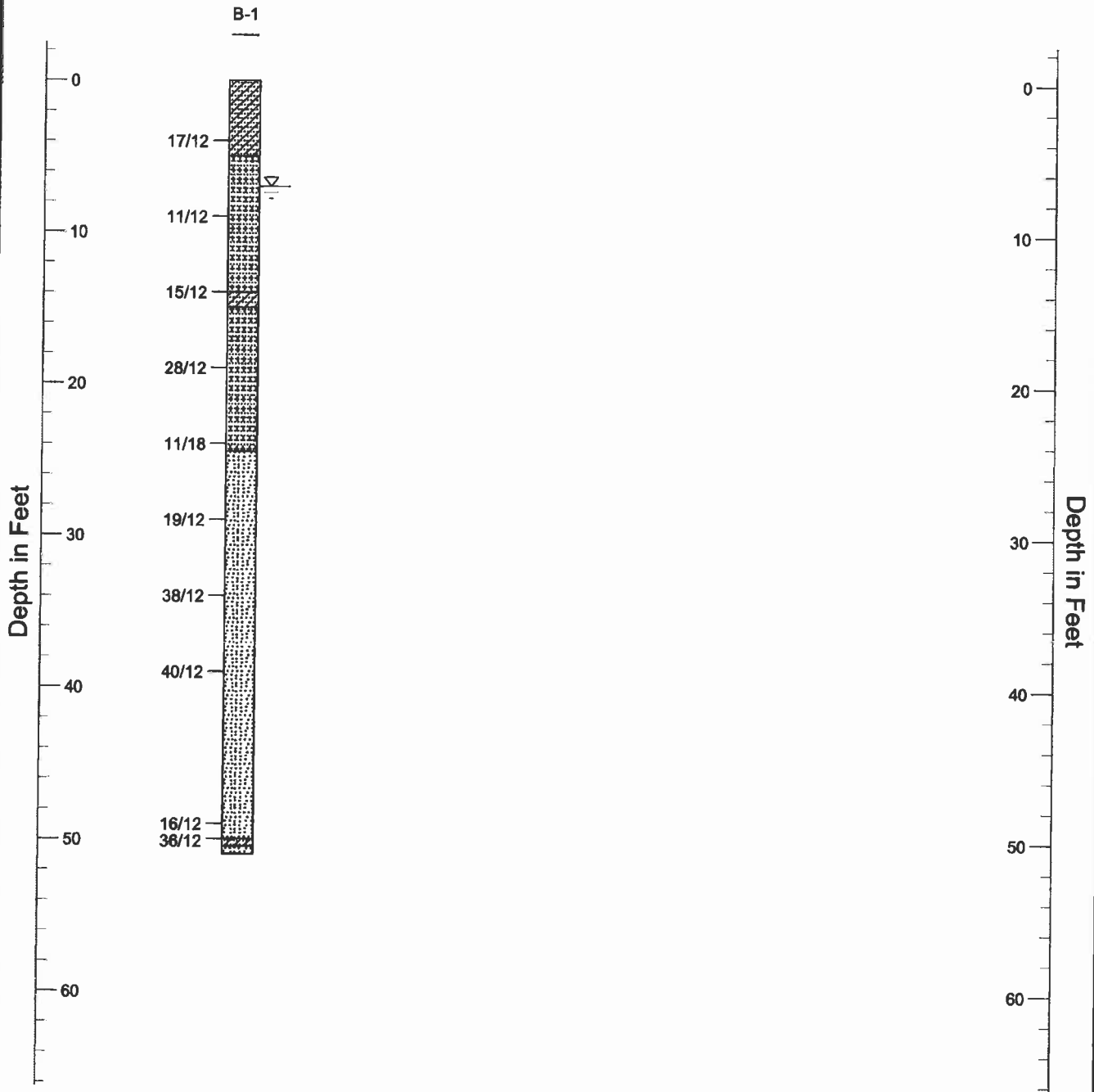
FIGURE 1
VICINITY MAP
CHERRY CREEK AT SHOP
CREEK TRAIL
PROJECT NO. D09.163





- KEY NOTES:**
- 1 RESTORE 870 LF OF ACCESS ROAD. SEE DETAIL 1/D-1 AND SPECIFICATION SECTION 02130.
 - 2 RESTORE 1485 LF OF ACCESS PATH. SEE DETAIL 2/D-1 AND SPECIFICATION SECTIONS 02130 AND 02700.
 - 3 RESTORE CONTRACTOR STORAGE AREA. SEE SPECIFICATION SECTIONS 02130 AND 02700.
 - 4 REPLACE EXISTING CLAYMERT WITH 1 1/2" CMP. SEE SPECIFICATION SECTION 02130.
 - 5 REMOVE AND REPLACE (2) 10'x10' DAMAGED CONCRETE PATH SECTIONS.
 - 6 RESTORE 100 LF OF UNIMPROVED AREA. SEE SPECIFICATION SECTIONS 02130 AND 02700.
 - 7 RESTORE CREEK CROSSING. SEE DRAWINGS 0-1 THROUGH 0-4 FOR CHANNEL RESTORATION. SEE SPECIFICATION SECTIONS 02130 AND 02200 FOR FISH-CHANNEL RESTORATION.

<p>SCALE IN FEET</p>	<p>Explanation</p> <p>Location of Test Hole</p>	<p>Base Map from Integra Engineering Dated 7/24/09</p>	<p>FIGURE 2 SITE PLAN CHERRY CREEK AT SHOP CREEK TRAIL PROJECT NO. D09.163</p>	 Geotechnical Engineering Consultants	 Construction Materials Testing & Inspection
----------------------	--	--	--	--	---



NOTES: 17/12 indicates that 17 blows of a 140 pound hammer falling 30 inches were required to drive a 2-inch diameter sampler 12 inches.



CLIENT	Brown and Caldwell	DATE:	11/12/2009
PROJECT	Cherry Creek at Shop Creek Trail	JOB NO.:	D09.163
DESCRIPTION	Log of Test Hole	FIGURE:	3

KEY TO SYMBOLS

Symbol Description

Strata symbols



SAND, clayey, medium dense to dense to CLAY, sandy, very stiff to hard, medium plasticity, moist to wet, brown (SC to CL). The upper 3 to 5 feet contains up to 6-inch diameter cobbles.



SAND, clean, medium dense to dense, poorly graded, fine to medium grained, wet, light brown (SP).



SAND, clean, medium dense to dense, well graded, wet, light brown to light gray (SW).

Misc. Symbols



Water table during drilling

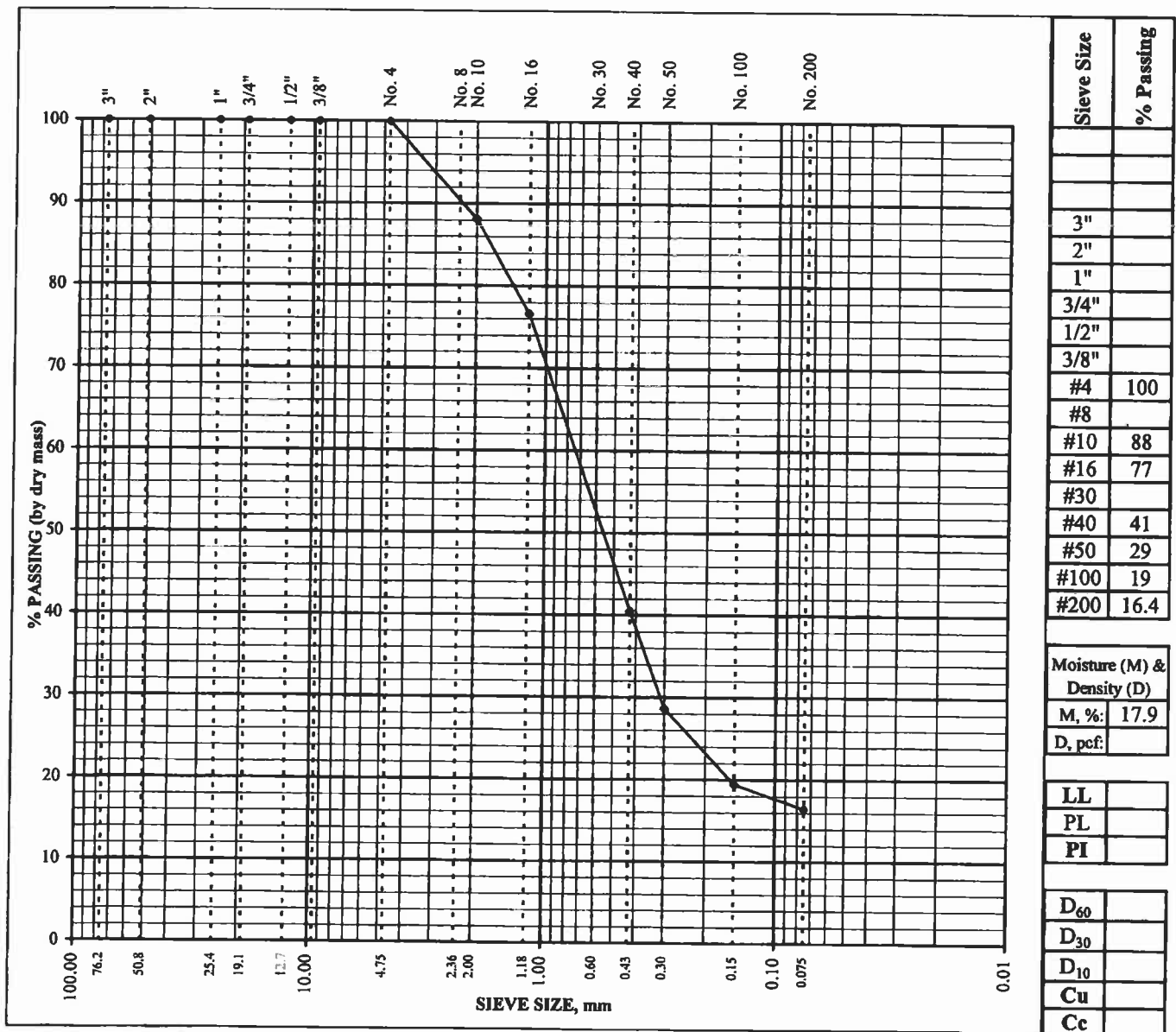
Notes:

1. Exploratory borings were drilled on September 2, 2009 using a 6-inch diameter hollow stem auger.
2. These logs are subject to the limitations, conclusions, and recommendations in this report.

GRADATION PLOT - SOIL & AGGREGATE

Project Number: D09.163, Brown and Caldwell Date: 3-Sep-09
 Project Name: Cherry Creek at Shop Creek Trail Technician: jpc
 Lab ID Number: 92729 Reviewer: drd
 Sample Location: B-1 at 14'
 Description: SAND with clay, very moist, brown

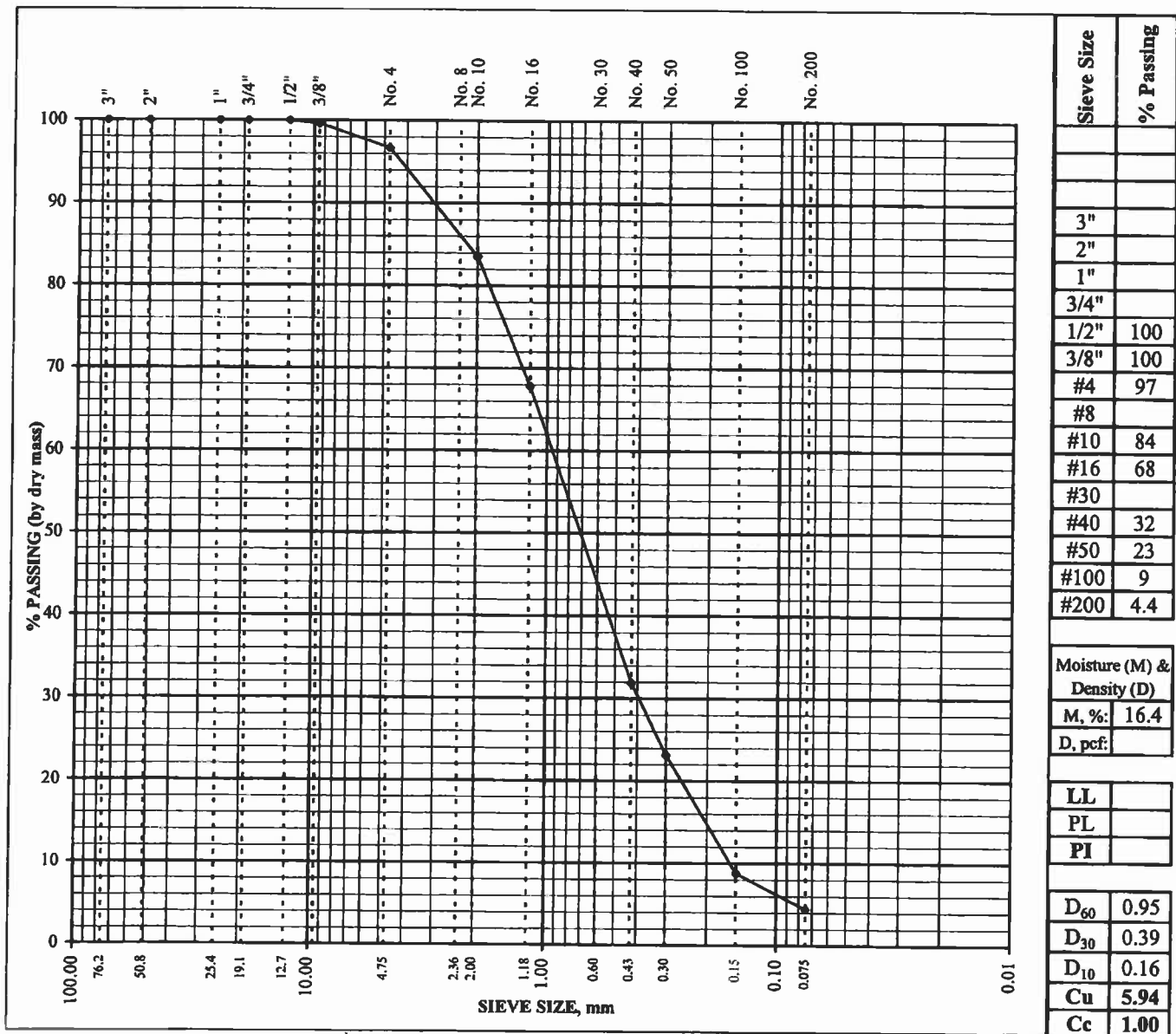
AASHTO M 145 Classification: A-1-b Group Index: _____
 Unified Soil Classification System
 (ASTM D 2487): (SC) Clayey sand



GRADATION PLOT - SOIL & AGGREGATE

Project Number: D09.163, Brown and Caldwell Date: 3-Sep-09
 Project Name: Cherry Creek at Shop Creek Trail Technician: jpc
 Lab ID Number: 92730 Reviewer: drd
 Sample Location: B-1 at 24'
 Description: SAND, very moist, light brown

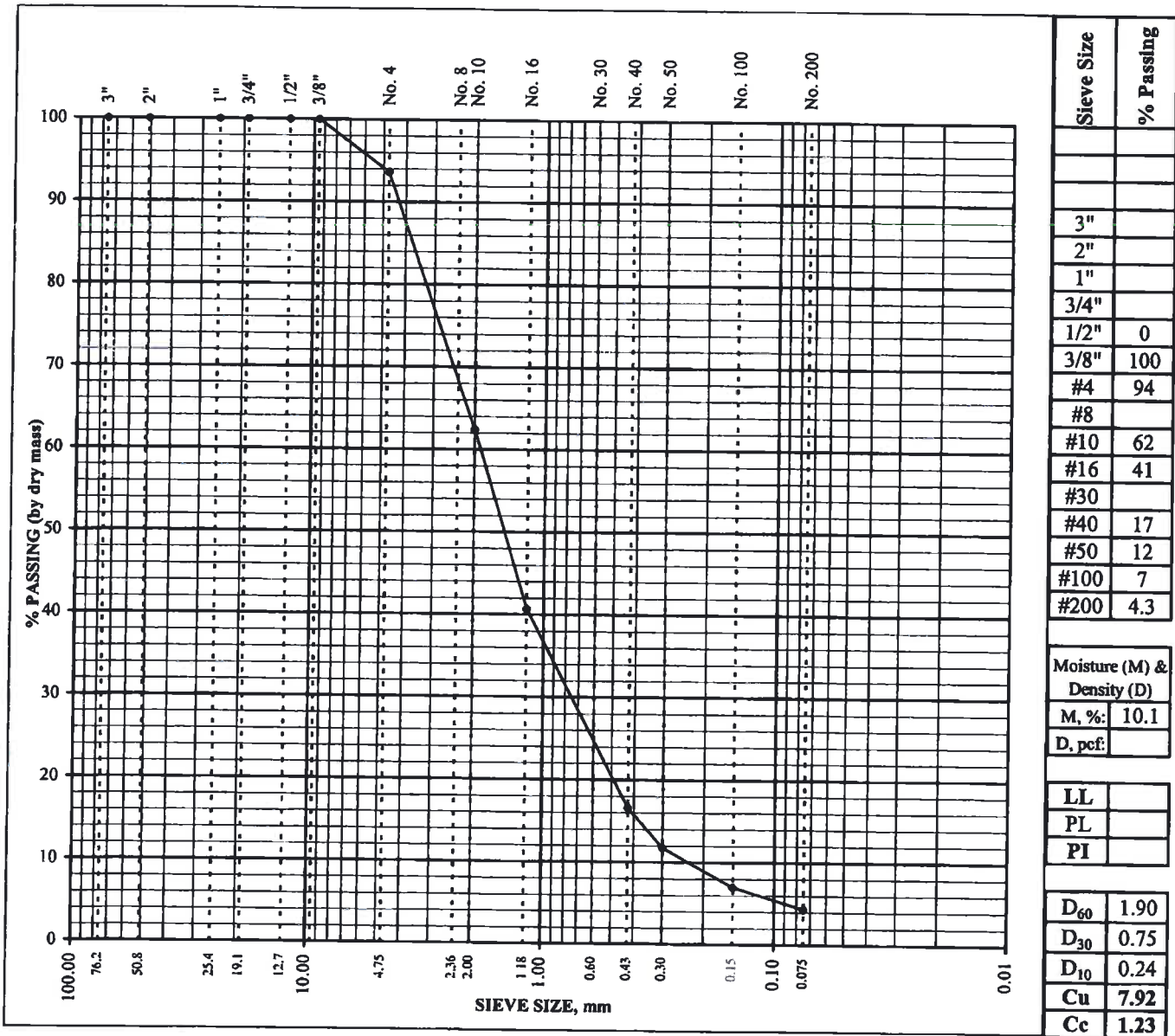
AASHTO M 145 Classification: A-1-b **Group Index:** _____
Unified Soil Classification System
(ASTM D 2487): (SP) **Poorly graded sand**



GRADATION PLOT - SOIL & AGGREGATE

Project Number: D09.163. Brown and Caldwell Date: 3-Sep-09
 Project Name: Cherry Creek at Shop Creek Trail Technician: jpc
 Lab ID Number: 92731 Reviewer: drd
 Sample Location: B-1 at 39'
 Description: SAND, very moist, light brown

AASHTO M 145 Classification: A-1-b Group Index: _____
 Unified Soil Classification System
 (ASTM D 2487): (SW) Well graded sand



ATTACHMENT D
HEC-RAS MODEL INPUT FOR SELECTED ALTERNATIVE
(INCLUDING CROSS-SECTION PLOTS)

Option 1 - 6-1-10

XSs 1 - 10 and 16-19

Geometries equal existing conditions

note: XSs 16-19 in May 10 RAS model are equivalent to 15-18 in the existing conditions RAS model

Riffle 1										Assumptions		
XS 11.1			XS 11.2			XS 11.3			XS 11.4		CAD Bank El. 5562.5	1 All XSs are 7' in depth ; assuming that any grading above 7' will not be rip-rapped 2 The 4 sections of ea. Riffle hover around the CAD elevation of the bank; most d/s XS is under, most u/s is over.
Thalweg	5553.5		Thalweg	5553		Thalweg	5554.5		Thalweg	5554.5		
x	y		x	y		x	y		x	y		
0	5560.5		0	5560		0	5561.5		0	5561.5		
28	5553.5		28	5553		28	5554.5		28	5554.5		
44	5553.5		44	5553		44	5554.5		44	5554.5		
72	5560.5		72	5560		72	5561.5		72	5561.5		
Riffle 2												
XS 12.1			XS 12.2			XS 12.3			XS 12.4		CAD Bank El. 5562.7	
Thalweg	5554.595		Thalweg	5554.095		Thalweg	5555.595		Thalweg	5555.595		
x	y		x	y		x	y		x	y		
0	5561.595		0	5561.095		0	5562.595		0	5562.595		
28	5554.595		28	5554.095		28	5555.595		28	5555.595		
44	5554.595		44	5554.095		44	5555.595		44	5555.595		
72	5561.595		72	5561.095		72	5562.595		72	5562.595		
Riffle 3												
XS 13.1			XS 13.2			XS 13.3			XS 13.4		CAD Bank El. 5564	
Thalweg	5555.705		Thalweg	5555.205		Thalweg	5556.705		Thalweg	5556.705		
x	y		x	y		x	y		x	y		
0	5562.705		0	5562.205		0	5563.705		0	5563.705		
28	5555.705		28	5555.205		28	5556.705		28	5556.705		
44	5555.705		44	5555.205		44	5556.705		44	5556.705		
72	5562.705		72	5562.205		72	5563.705		72	5563.705		
Riffle 4												
XS 14.1			XS 14.2			XS 14.3			XS 14.4		CAD Bank El. 5564.5	
Thalweg	5556.788		Thalweg	5556.288		Thalweg	5557.788		Thalweg	5557.788		
x	y		x	y		x	y		x	y		
0	5563.788		0	5563.288		0	5564.788		0	5564.788		
28	5556.788		28	5556.288		28	5557.788		28	5557.788		
44	5556.788		44	5556.288		44	5557.788		44	5557.788		
72	5563.788		72	5563.288		72	5564.788		72	5564.788		
Riffle 5												
XS 15.1			XS 15.2			XS 15.3			XS 15.4		CAD Bank El. 5565	
Thalweg	5557.878		Thalweg	5557.378		Thalweg	5558.878		Thalweg	5558.878		
x	y		x	y		x	y		x	y		
0	5564.878		0	5564.378		0	5565.878		0	5565.878		
28	5557.878		28	5557.378		28	5558.878		28	5558.878		
44	5557.878		44	5557.378		44	5558.878		44	5558.878		
72	5564.878		72	5564.378		72	5565.878		72	5565.878		

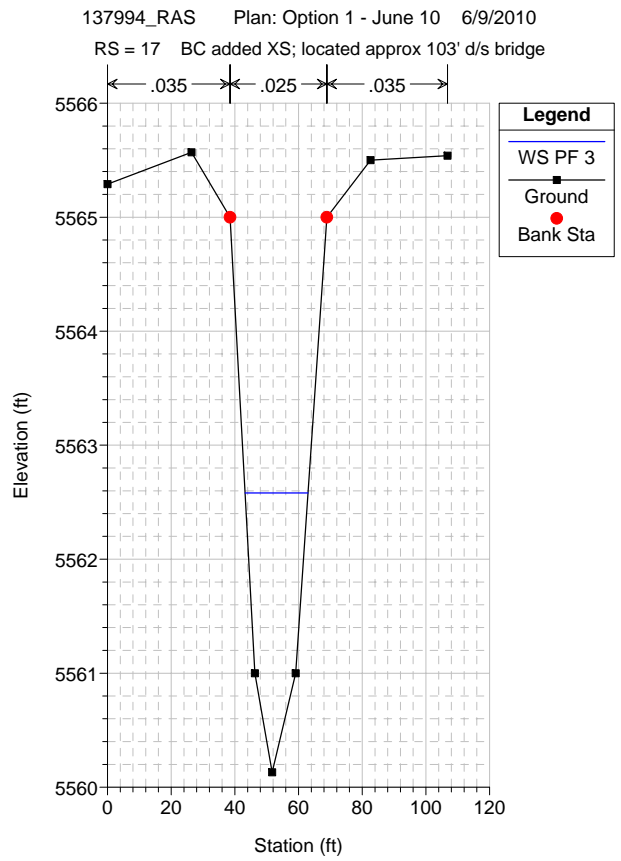
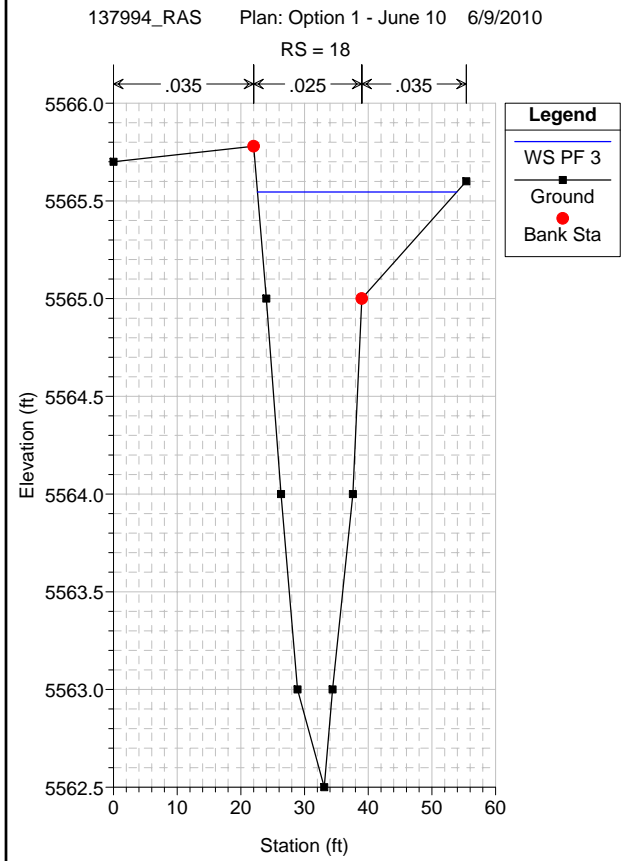
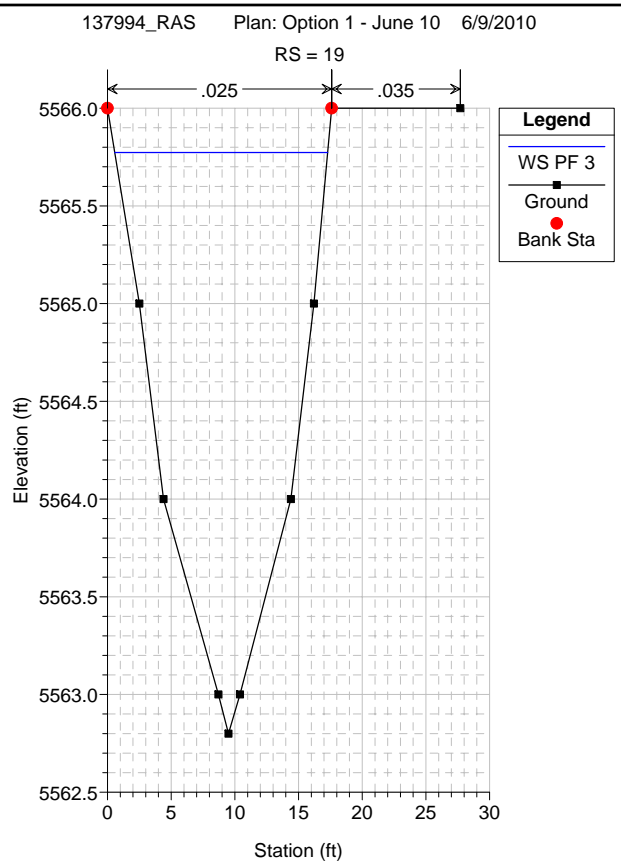
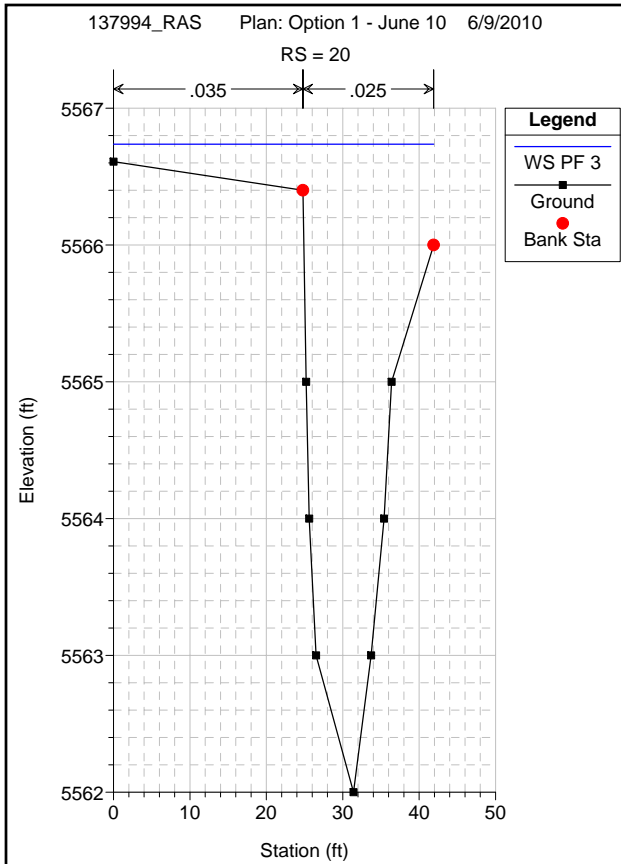
Note: u/s of XS is the stilling pool for the aurora rip-rap area

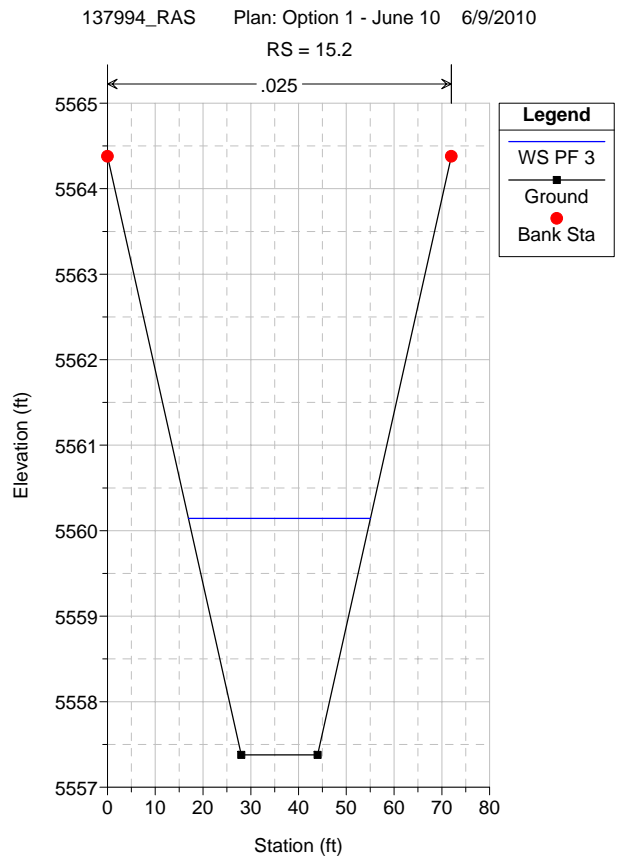
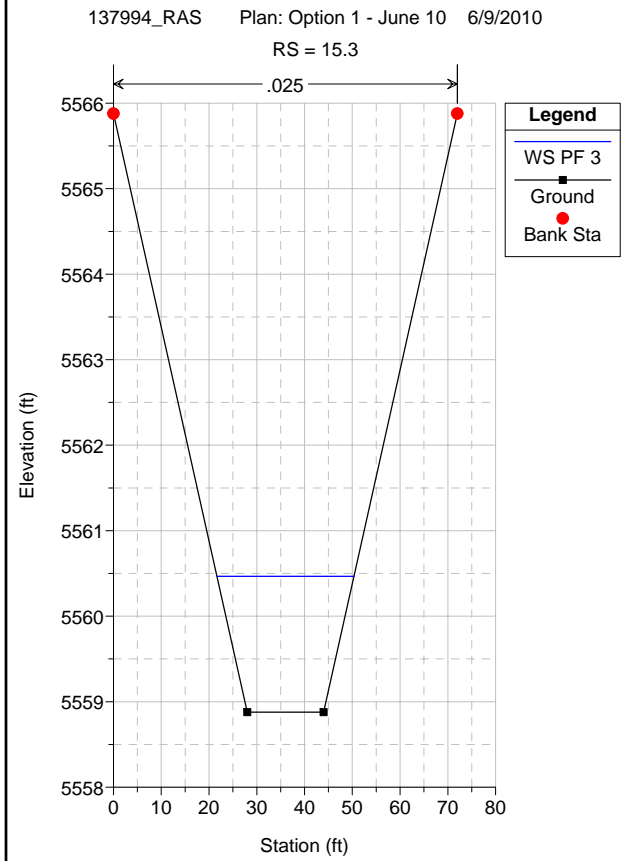
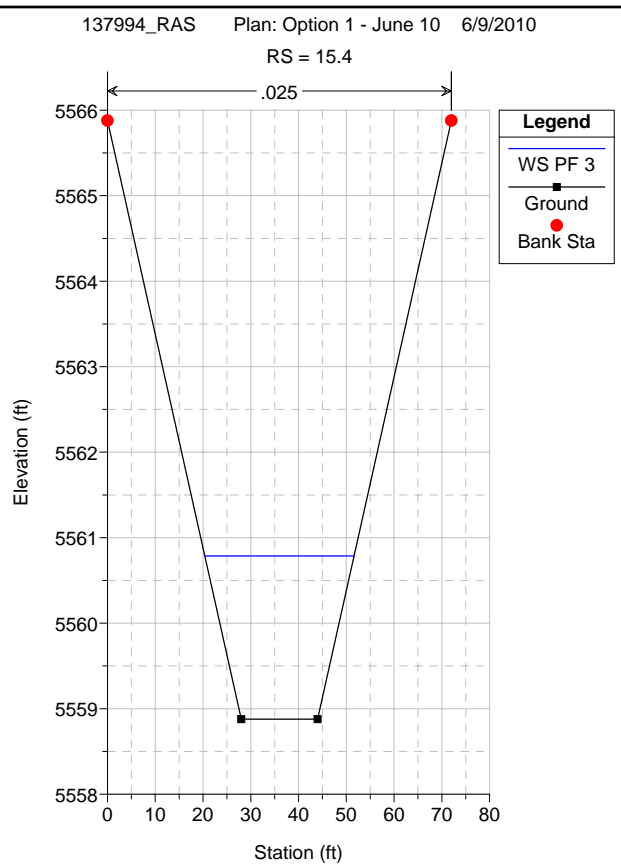
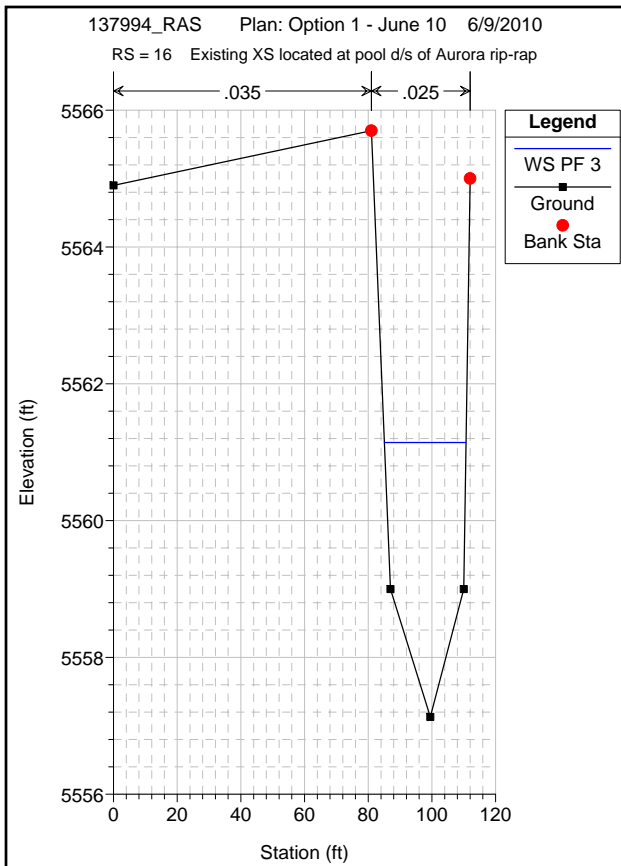
Distances

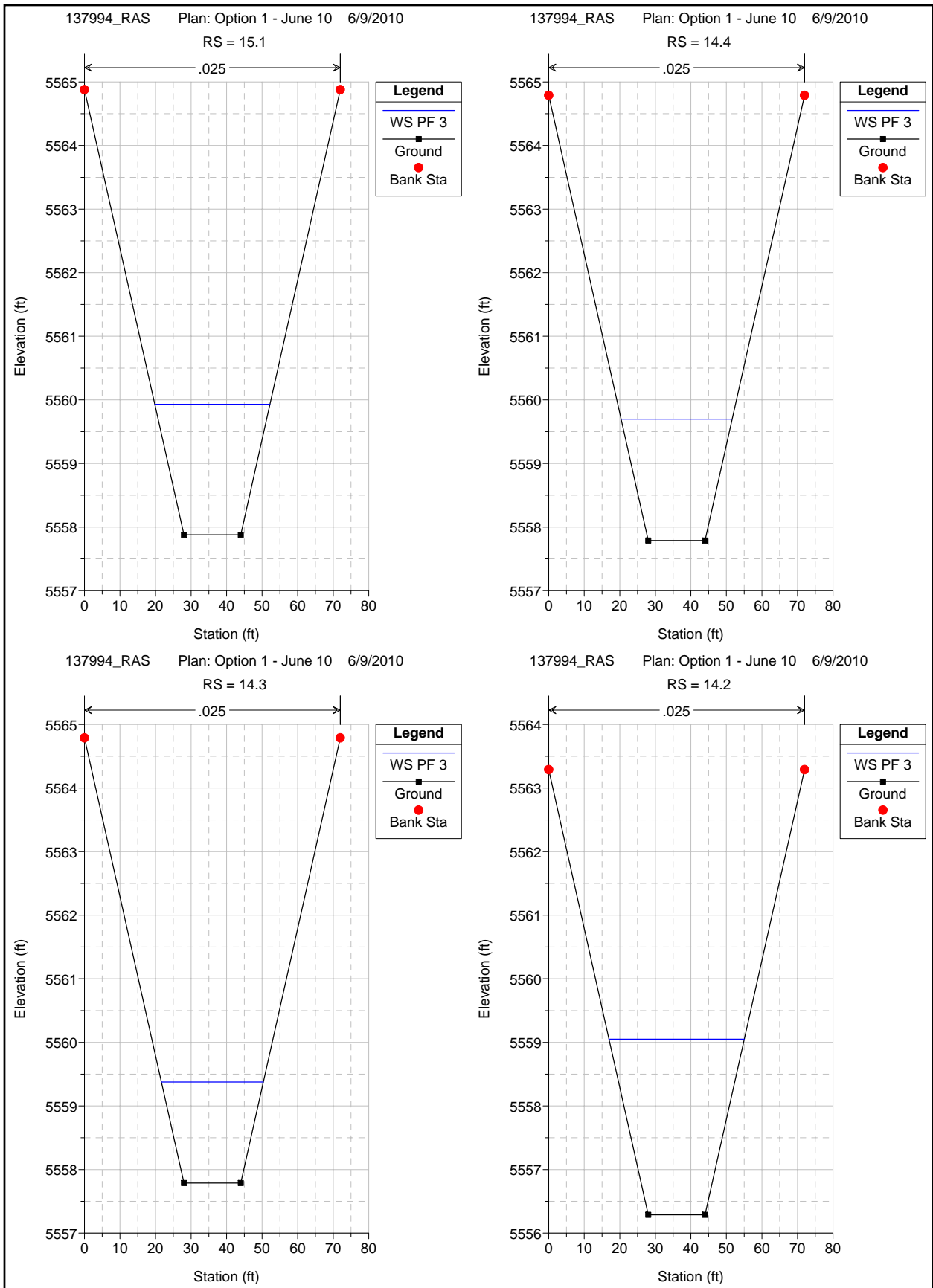
XS	d/s channel length	ROB	LOB	
0.5	0	0	0	
1	108	108	108	
2	137	137	137	
3	116	116	116	
4	99	99	99	
5	73	73	73	
6	84	84	84	
7	150	150	150	
8	96	96	96	
9	82	82	82	
10	126	126	126	
11.1	80	80	80	riffle 1
11.2	10	10	10	
11.3	35	35	35	
11.4	10	10	10	
12.1	43	43	43	riffle 2
12.2	10	10	10	
12.3	35	35	35	
12.4	10	10	10	
13.1	50	50	50	riffle 3
13.2	10	10	10	
13.3	40	40	40	
13.4	10	10	10	
14.1	38	38	38	riffle 4
14.2	10	10	10	
14.3	35	35	35	
14.4	10	10	10	
15.1	41	41	41	riffle 5
15.2	10	10	10	
15.3	35	35	35	
15.4	10	10	10	
16	60	60	60	
17	27	27	27	
18	41	41	41	
19	27	27	27	
20	93	93	93	

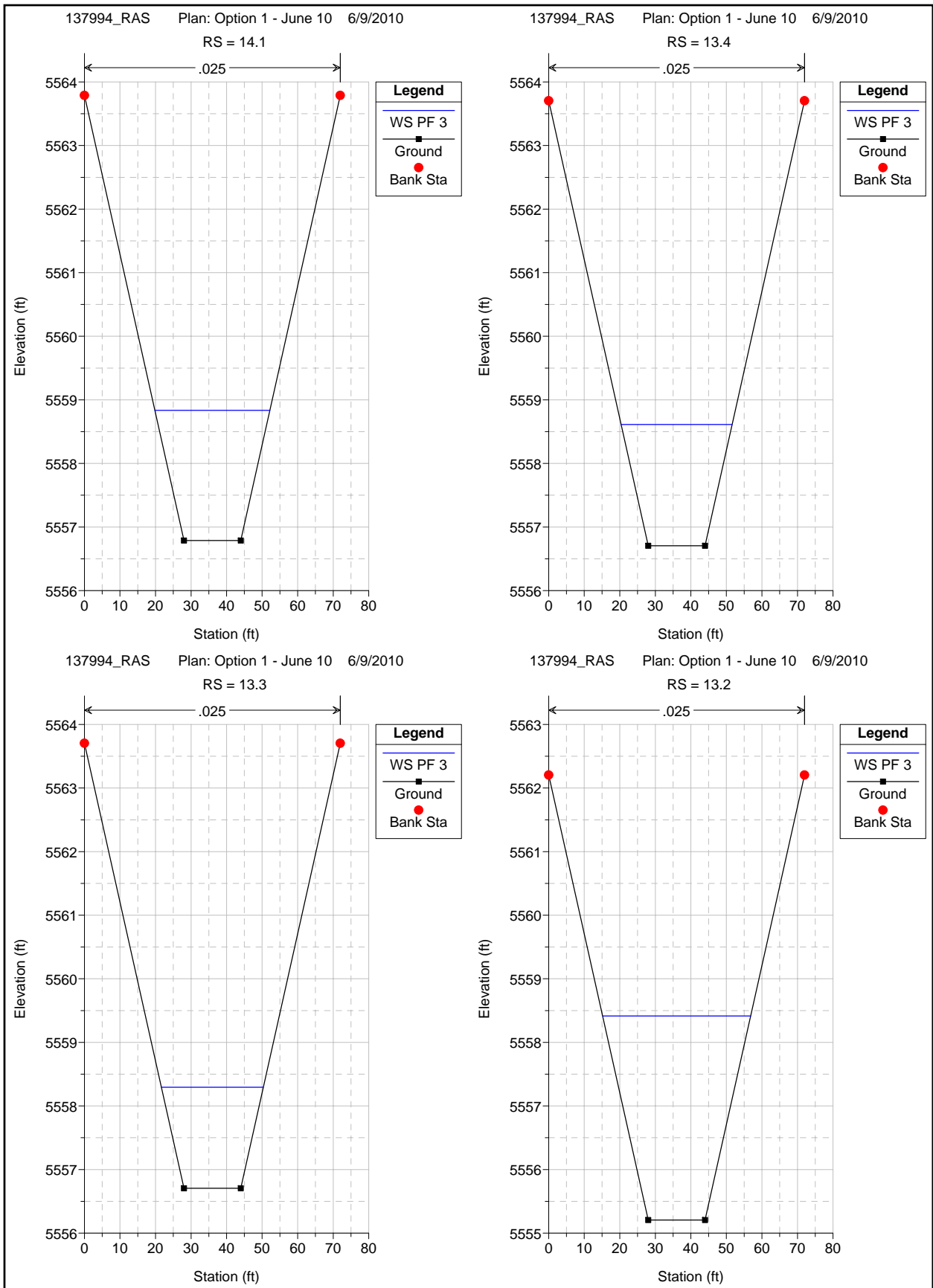
NEW EXISTING XS 16 - located at the pool just below the rip-rap section (XS 15 in Existing Conditions model)

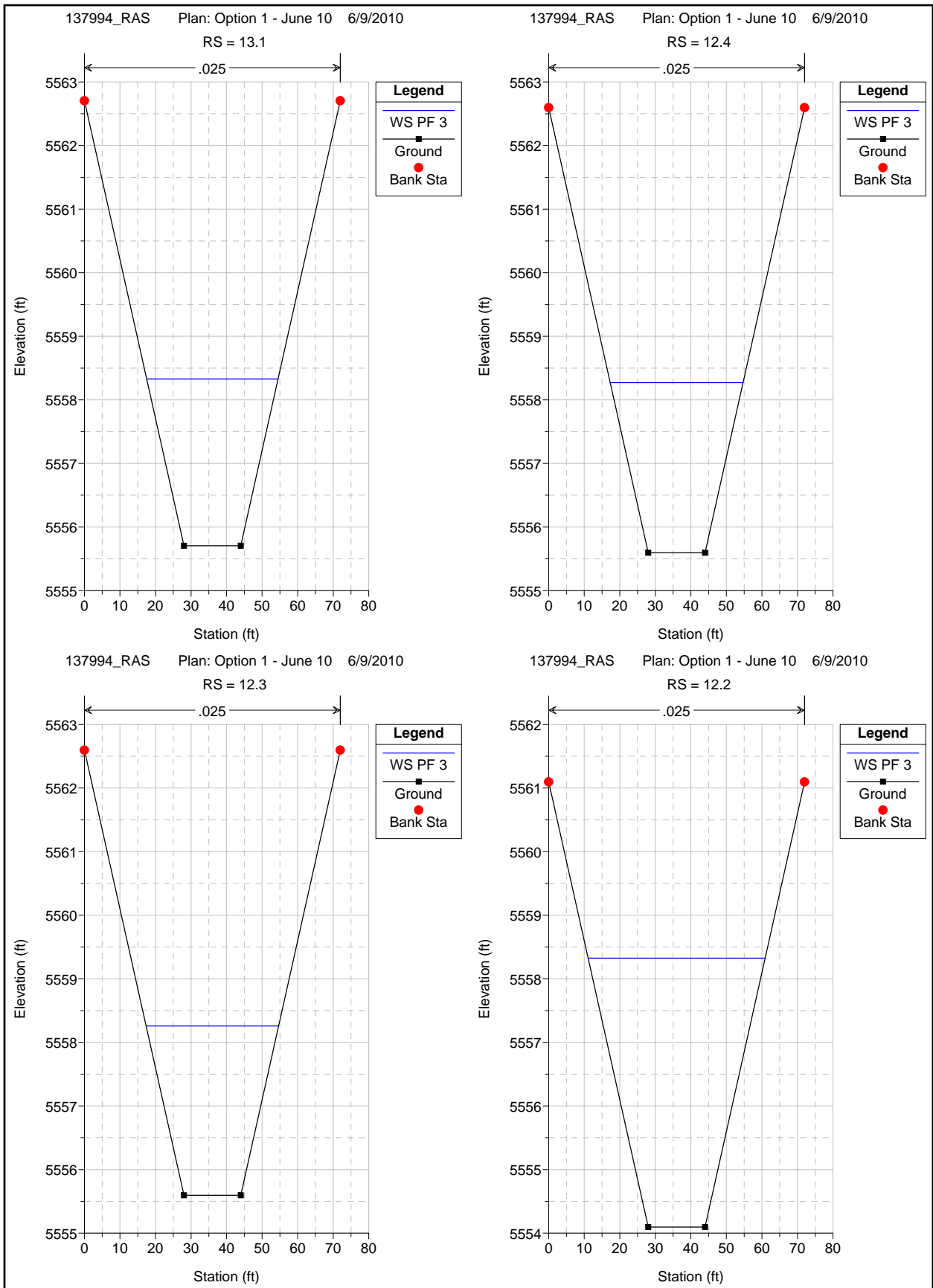
x	y		XS 16	129	27
0	5564.9	note: revised existing conditions model to include new XS	XS 16		
81	5565.7		XS 15		102
87	5559				
99.5	5557.13				
110	5559				
112	5565				

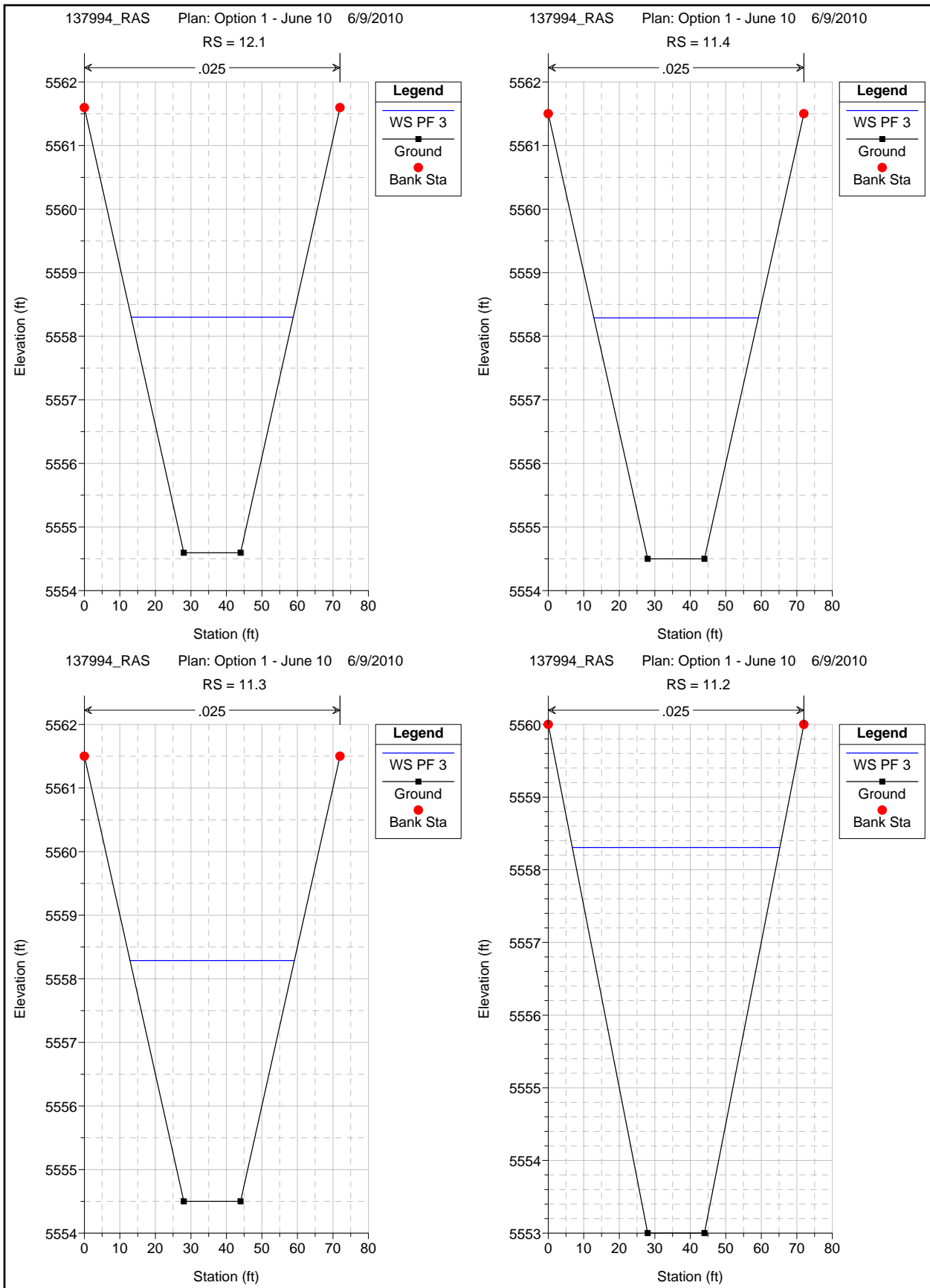


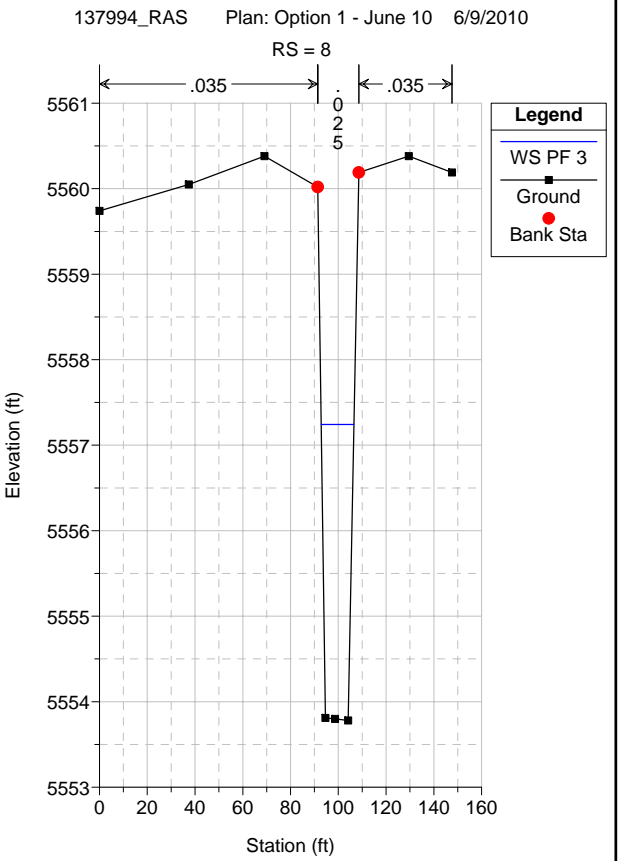
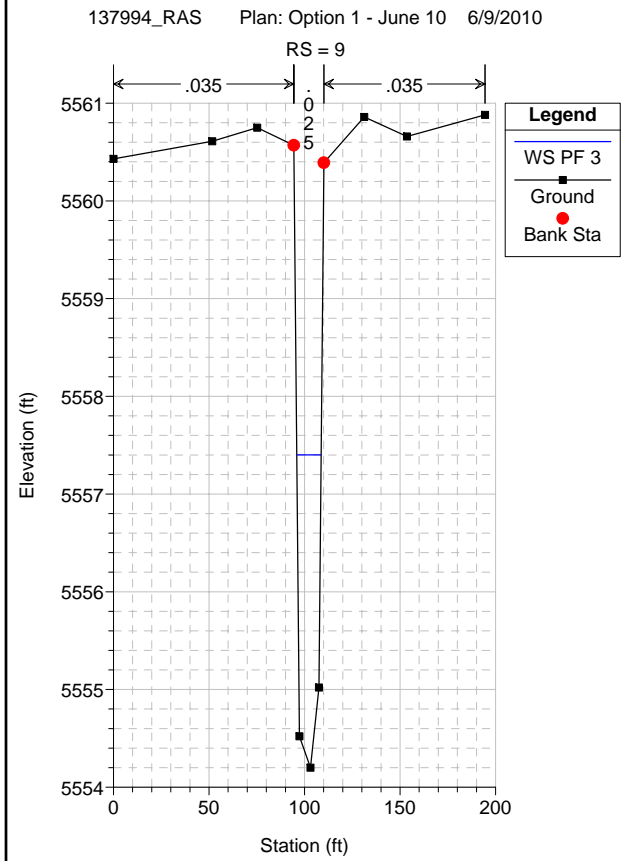
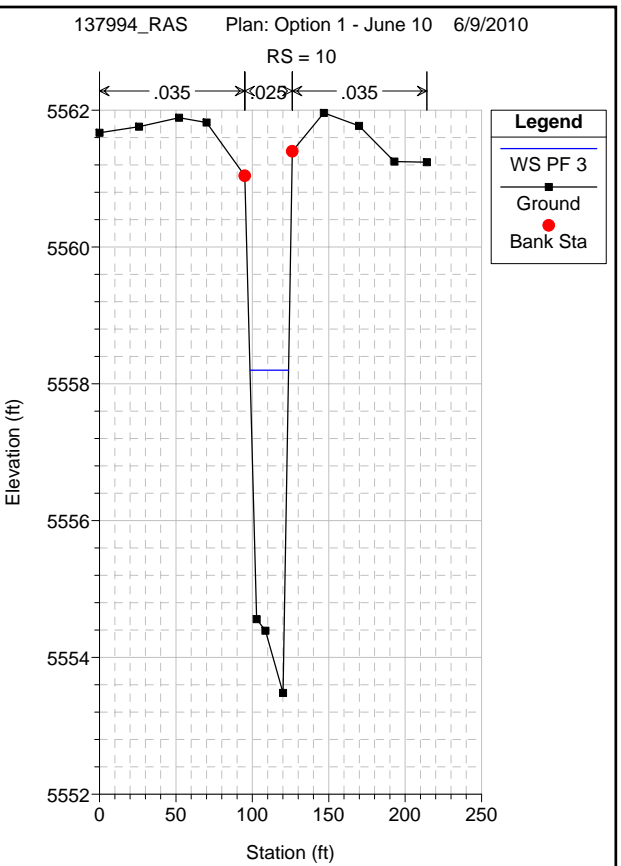
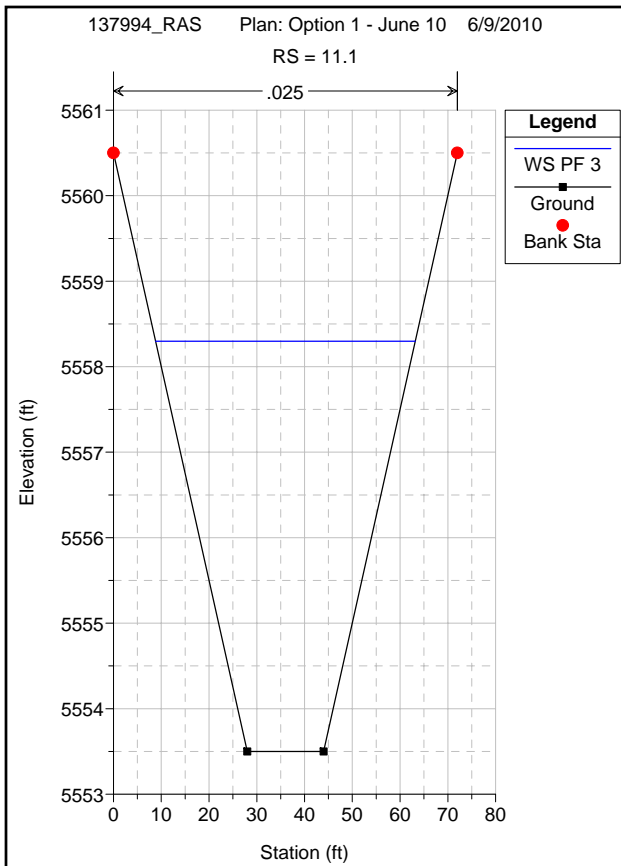


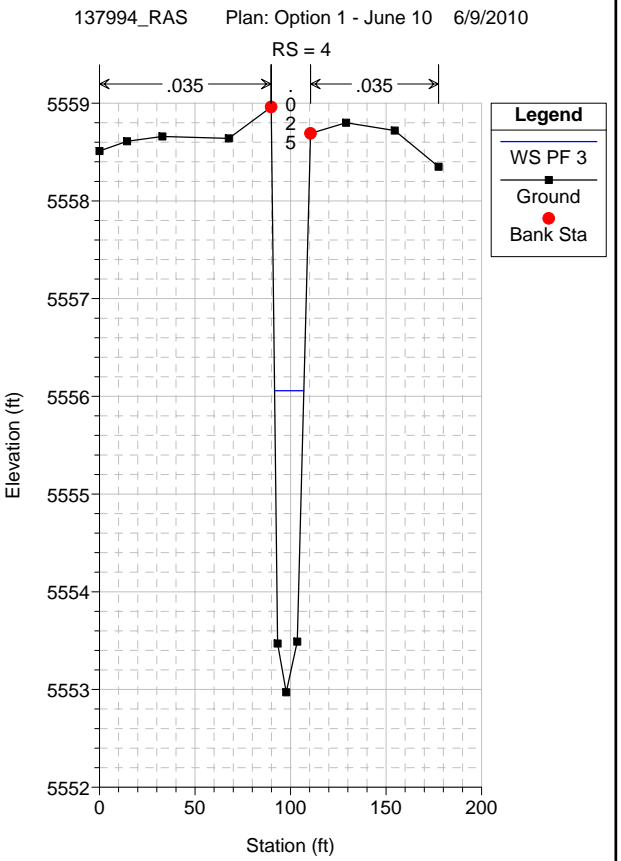
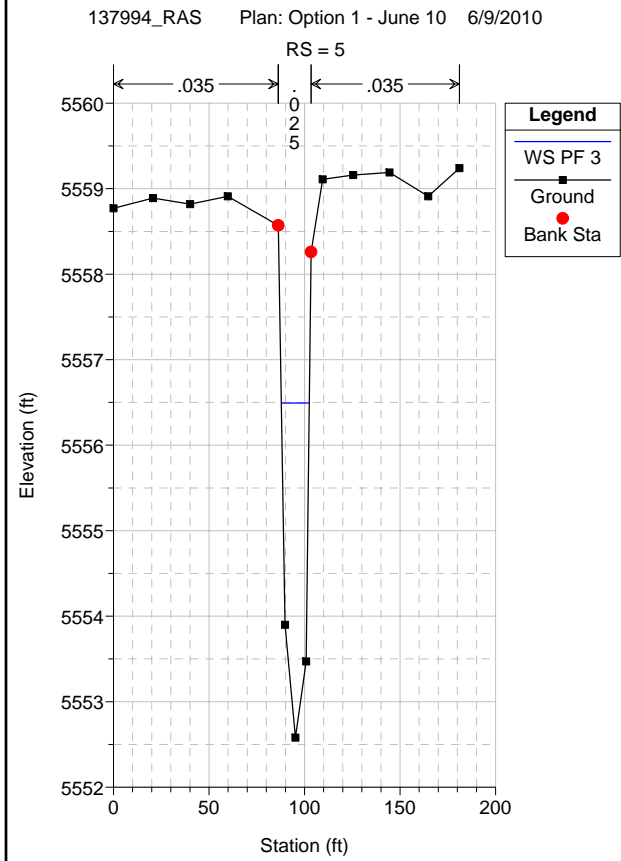
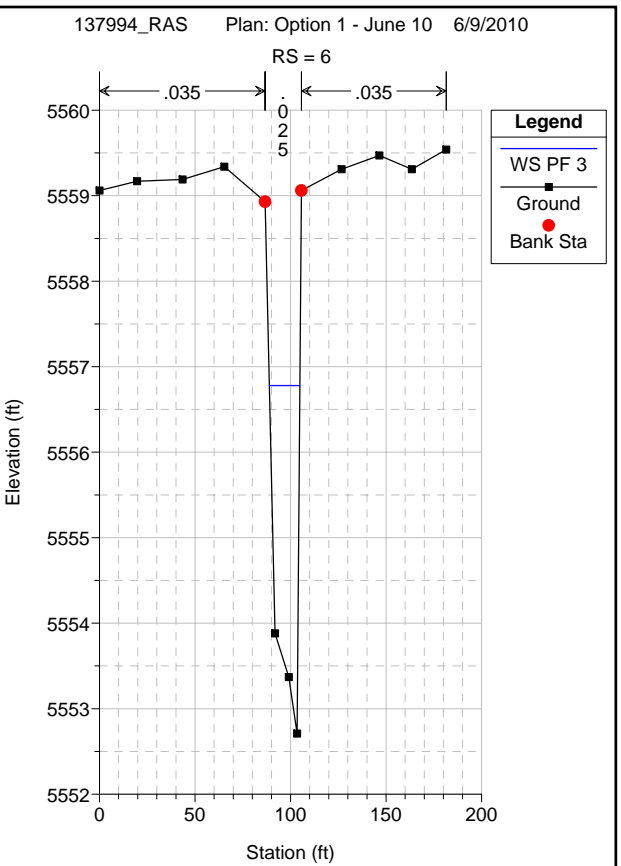
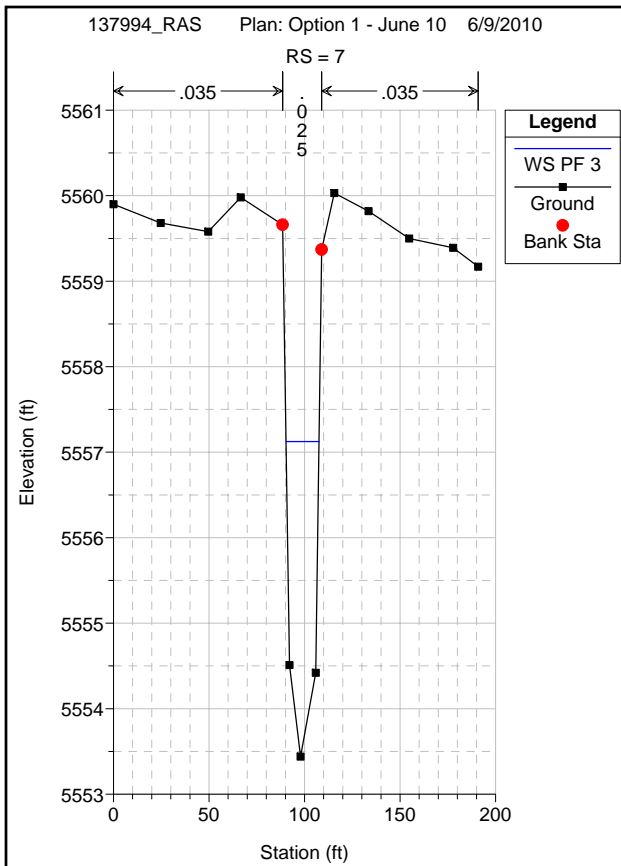


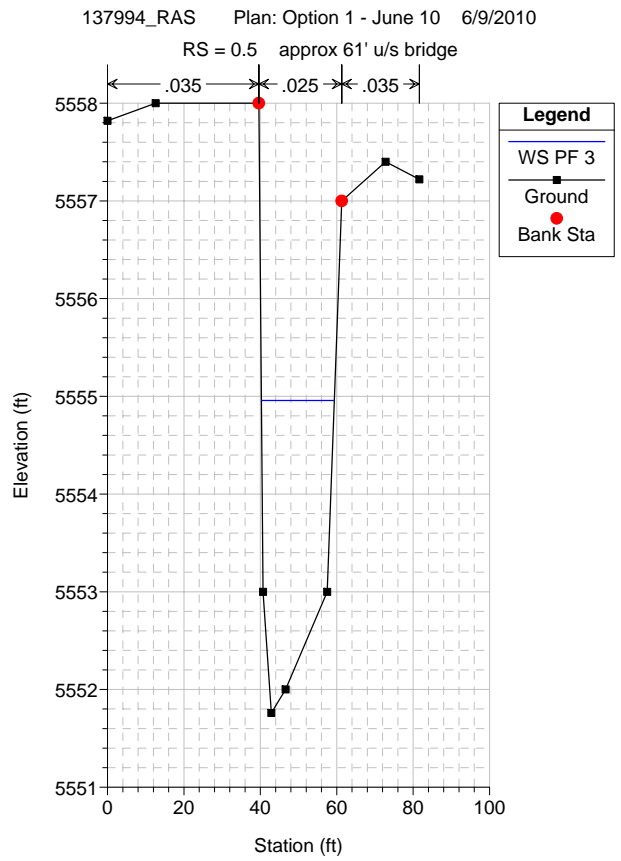
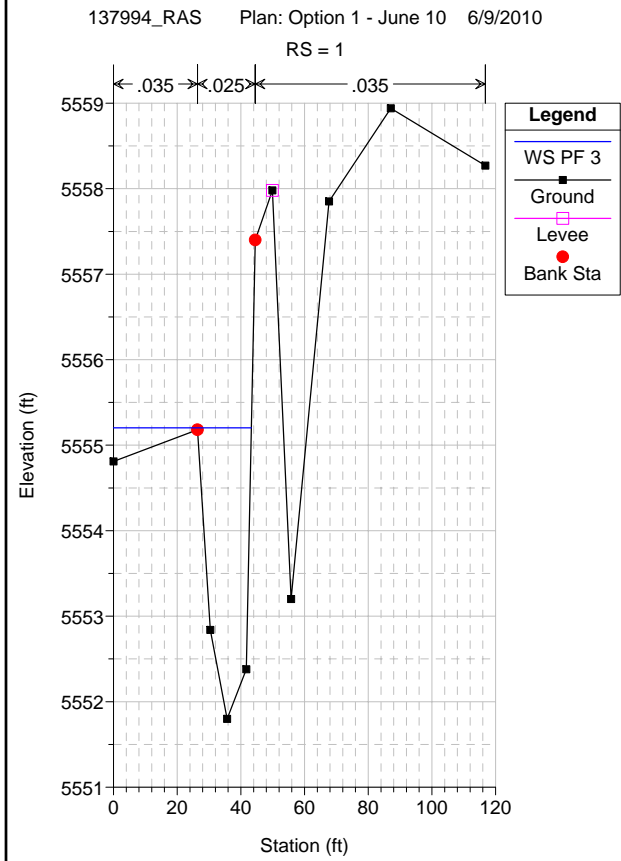
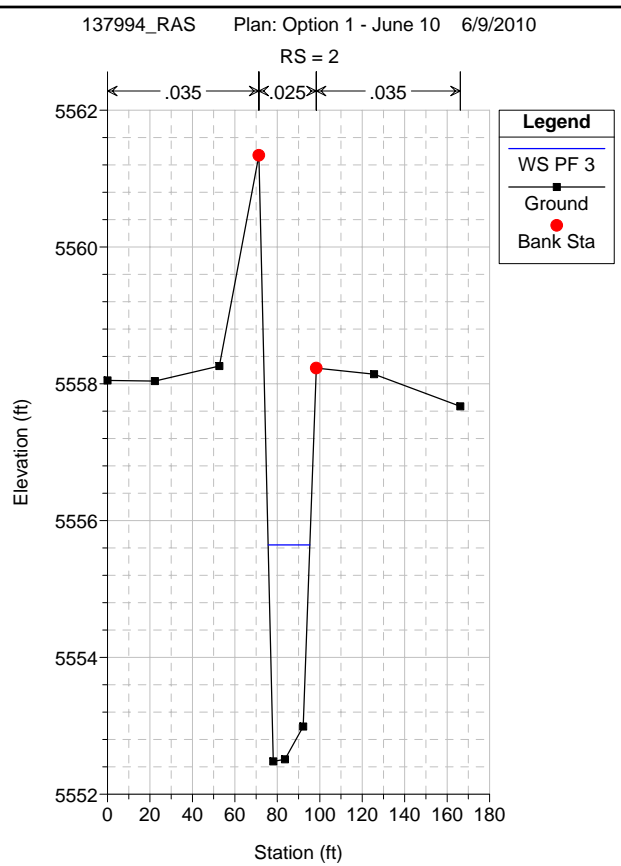
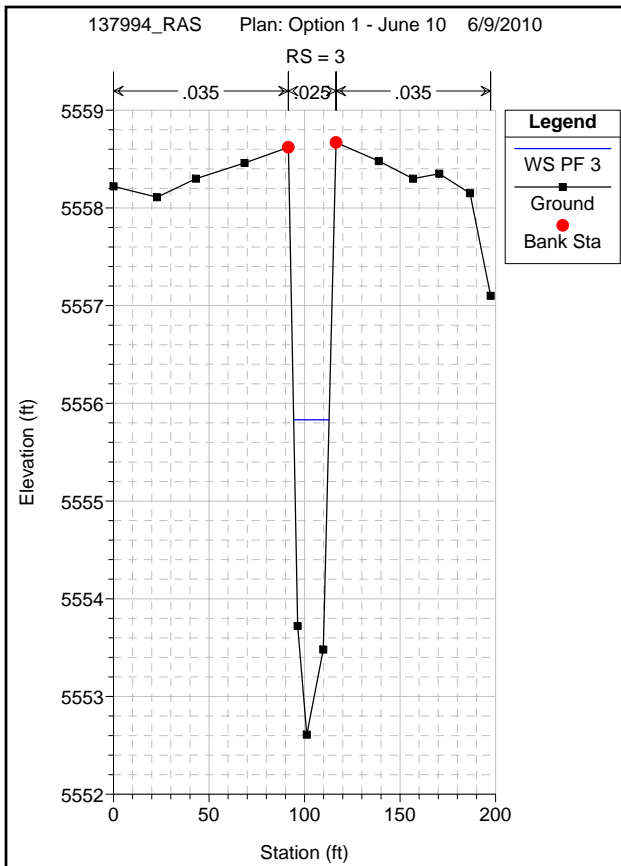












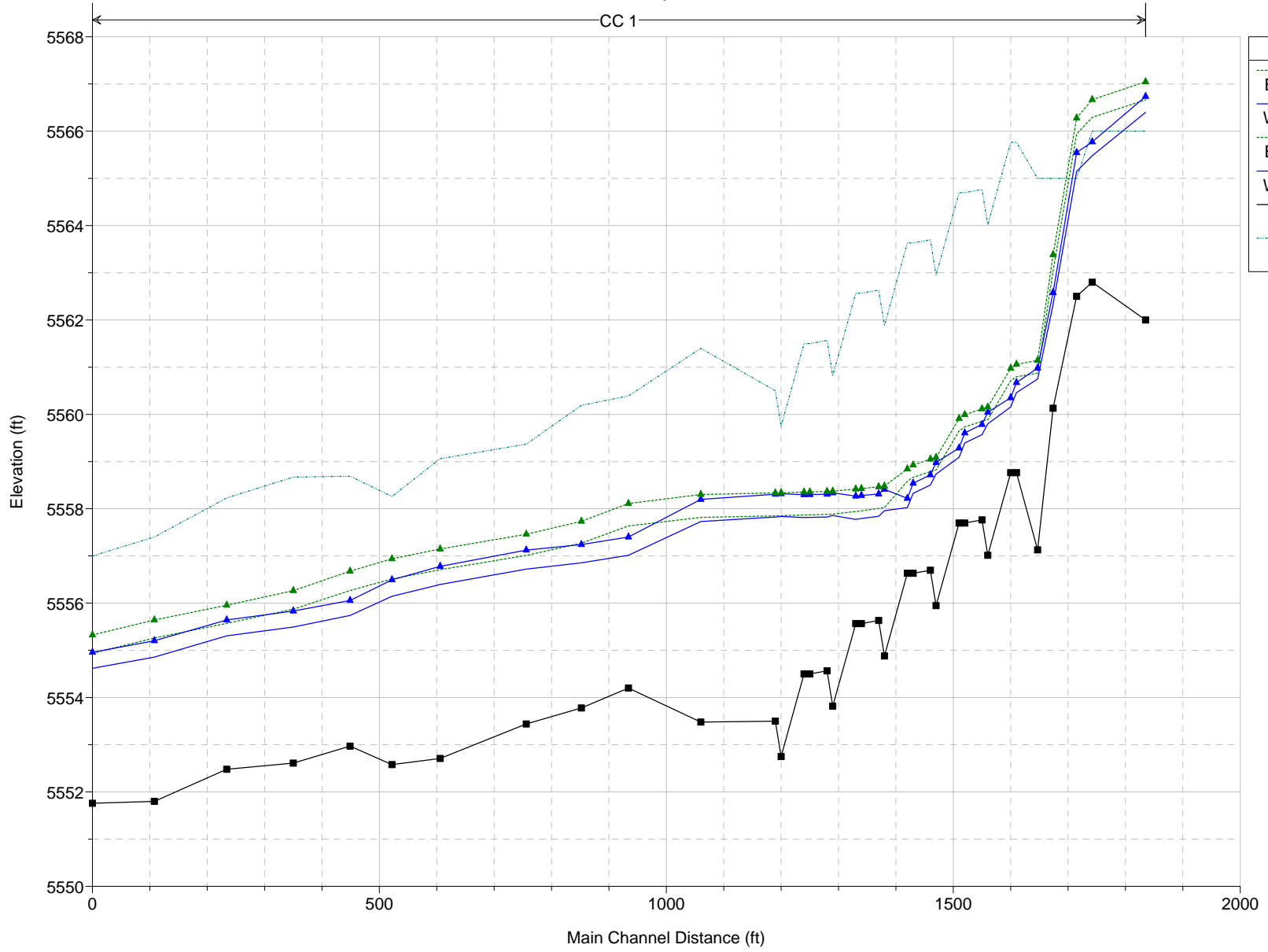
ATTACHMENT E

HEC-RAS MODEL OUPUT FOR SELECTED ALTERNATIVE
(INCLUDING PROFILE AND CROSS-SECTION PLOTS)

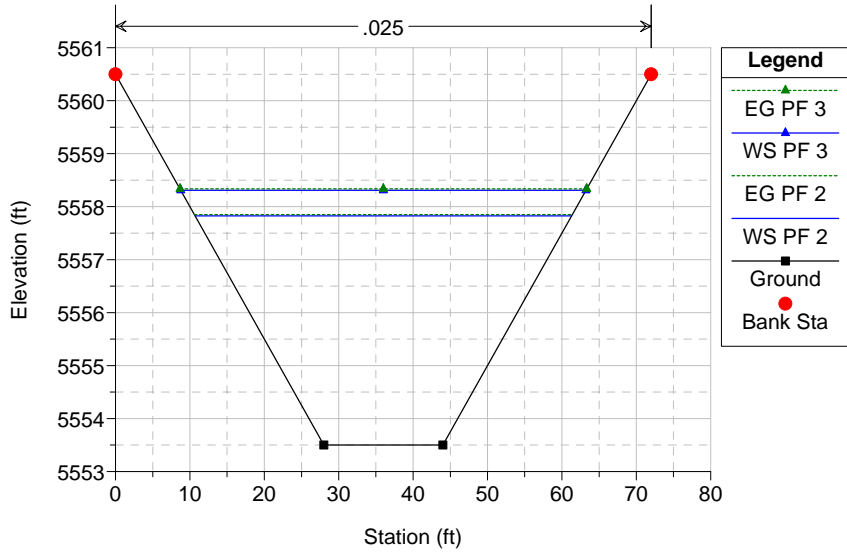
HEC-RAS Plan: Opt 1 - June River: CC Reach: 1 Profile: PF 3

Reach	River Sta	Profile	Q Total (cfs)	Min Ch El (ft)	W.S. Elev (ft)	Crit W.S. (ft)	E.G. Elev (ft)	E.G. Slope (ft/ft)	Vel Chnl (ft/s)	Flow Area (sq ft)	Top Width (ft)	Froude # Chl
1	20	PF 3	225.00	5562.00	5566.74		5567.04	0.001840	4.49	55.02	41.90	0.47
1	19	PF 3	225.00	5562.80	5565.77	5565.77	5566.67	0.008336	7.59	29.63	16.72	1.01
1	18	PF 3	225.00	5562.50	5565.55	5565.55	5566.28	0.006262	6.96	35.57	31.32	0.89
1	17	PF 3	225.00	5560.13	5562.58	5562.58	5563.38	0.008360	7.19	31.30	19.75	1.01
1	16	PF 3	225.00	5557.13	5561.14		5561.29	0.000745	3.06	73.58	25.63	0.32
1	15.4	PF 3	225.00	5558.88	5560.79	5560.46	5561.17	0.004411	4.99	45.10	31.27	0.73
1	15.3	PF 3	225.00	5558.88	5560.47	5560.47	5561.09	0.008728	6.34	35.49	28.70	1.00
1	15.2	PF 3	225.00	5557.38	5560.14		5560.28	0.001066	3.01	74.84	38.13	0.38
1	15.1	PF 3	225.00	5557.88	5559.93		5560.25	0.003357	4.53	49.67	32.41	0.64
1	14.4	PF 3	225.00	5557.79	5559.70	5559.37	5560.08	0.004407	4.99	45.11	31.27	0.73
1	14.3	PF 3	225.00	5557.79	5559.38	5559.38	5560.00	0.008718	6.34	35.51	28.71	1.00
1	14.2	PF 3	225.00	5556.29	5559.05		5559.19	0.001071	3.01	74.71	38.10	0.38
1	14.1	PF 3	225.00	5556.79	5558.83		5559.16	0.003390	4.55	49.49	32.37	0.65
1	13.4	PF 3	225.00	5556.71	5558.61	5558.29	5559.00	0.004411	4.99	45.10	31.27	0.73
1	13.3	PF 3	225.00	5556.71	5558.29	5558.29	5558.92	0.008708	6.33	35.52	28.71	1.00
1	13.2	PF 3	225.00	5555.21	5558.42		5558.51	0.000592	2.43	92.55	41.68	0.29
1	13.1	PF 3	225.00	5555.71	5558.33		5558.49	0.001311	3.24	69.47	36.98	0.42
1	12.4	PF 3	225.00	5555.60	5558.27		5558.43	0.001212	3.15	71.45	37.41	0.40
1	12.3	PF 3	225.00	5555.60	5558.26		5558.41	0.001236	3.17	70.96	37.30	0.41
1	12.2	PF 3	225.00	5554.10	5558.33		5558.37	0.000193	1.62	139.23	49.84	0.17
1	12.1	PF 3	225.00	5554.60	5558.30		5558.36	0.000332	1.97	114.19	45.64	0.22
1	11.4	PF 3	225.00	5554.50	5558.29		5558.35	0.000303	1.91	118.08	46.32	0.21
1	11.3	PF 3	225.00	5554.50	5558.29		5558.34	0.000304	1.91	117.94	46.29	0.21
1	11.2	PF 3	225.00	5553.00	5558.31		5558.33	0.000075	1.14	197.58	58.46	0.11
1	11.1	PF 3	225.00	5553.50	5558.30		5558.33	0.000114	1.33	168.84	54.38	0.13
1	10	PF 3	225.00	5553.48	5558.20		5558.30	0.000437	2.59	86.91	25.20	0.25
1	9	PF 3	225.00	5554.20	5557.40		5558.11	0.004928	6.76	33.27	12.73	0.74
1	8	PF 3	225.00	5553.78	5557.24		5557.73	0.003002	5.63	39.97	13.70	0.58
1	7	PF 3	225.00	5553.44	5557.13		5557.46	0.001911	4.64	48.51	17.32	0.49
1	6	PF 3	225.00	5552.71	5556.78		5557.15	0.002209	4.87	46.21	15.97	0.50
1	5	PF 3	225.00	5552.58	5556.49		5556.94	0.002610	5.36	41.99	14.58	0.56
1	4	PF 3	225.00	5552.97	5556.06		5556.68	0.004439	6.32	35.62	15.31	0.73
1	3	PF 3	225.00	5552.61	5555.83		5556.27	0.002965	5.29	42.57	18.55	0.61
1	2	PF 3	225.00	5552.48	5555.65		5555.96	0.001914	4.48	50.23	19.67	0.49
1	1	PF 3	225.00	5551.80	5555.20	5554.45	5555.65	0.003012	5.39	46.43	43.27	0.61
1	0.5	PF 3	225.00	5551.76	5554.96	5554.11	5555.33	0.002501	4.88	46.08	19.09	0.55

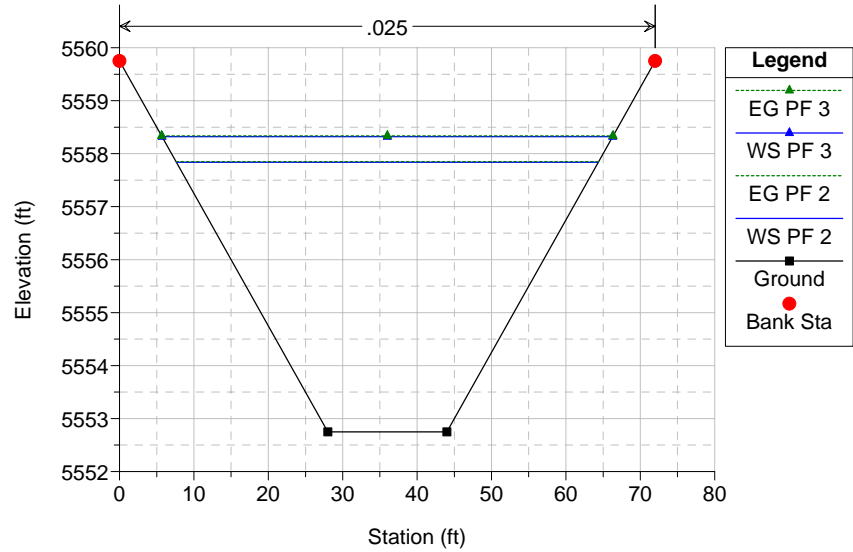
CC 1



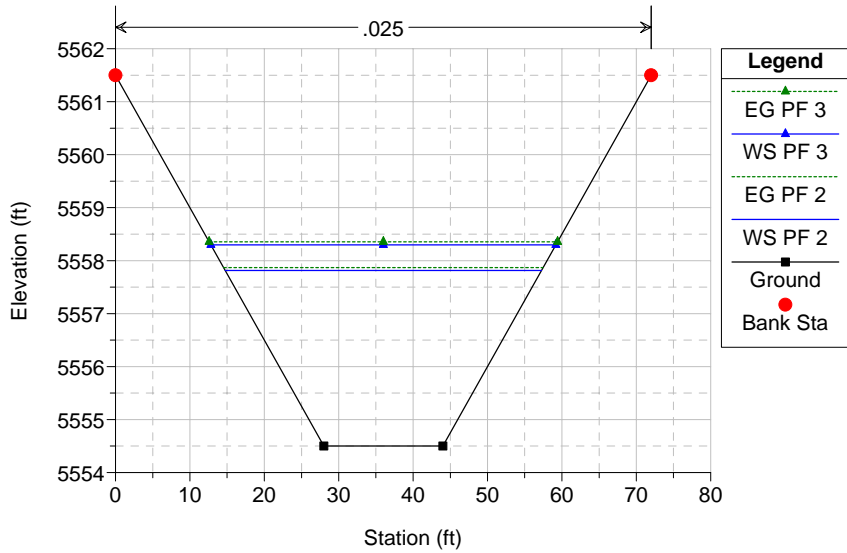
137994_RAS Plan: Option 1 - June 10 6/2/2010
RS = 11.1



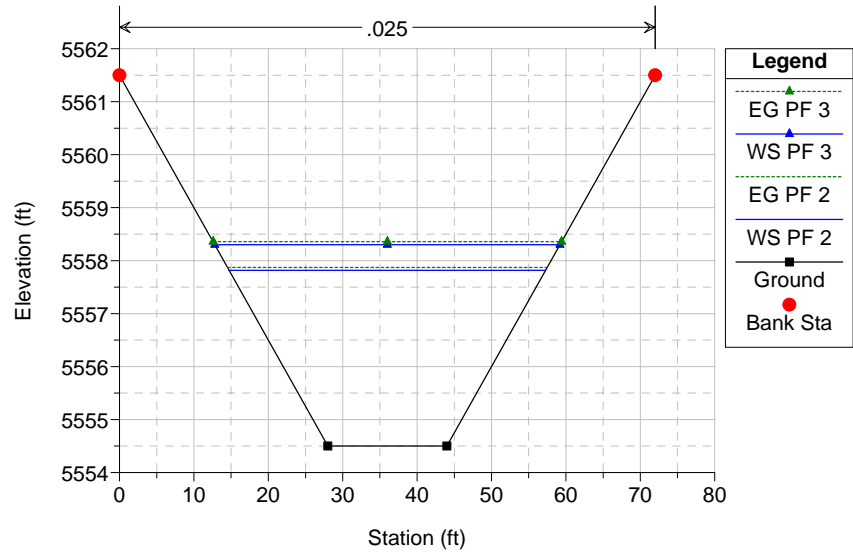
137994_RAS Plan: Option 1 - June 10 6/2/2010
RS = 11.2



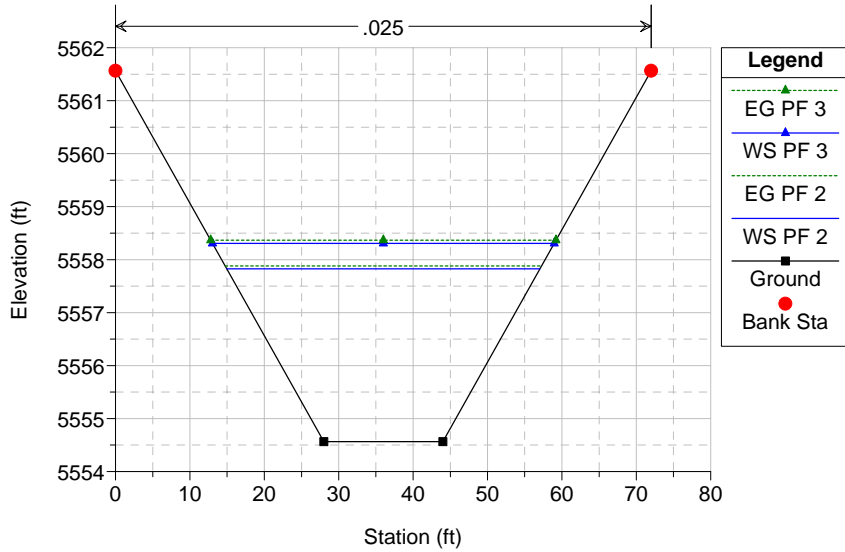
137994_RAS Plan: Option 1 - June 10 6/2/2010
RS = 11.3



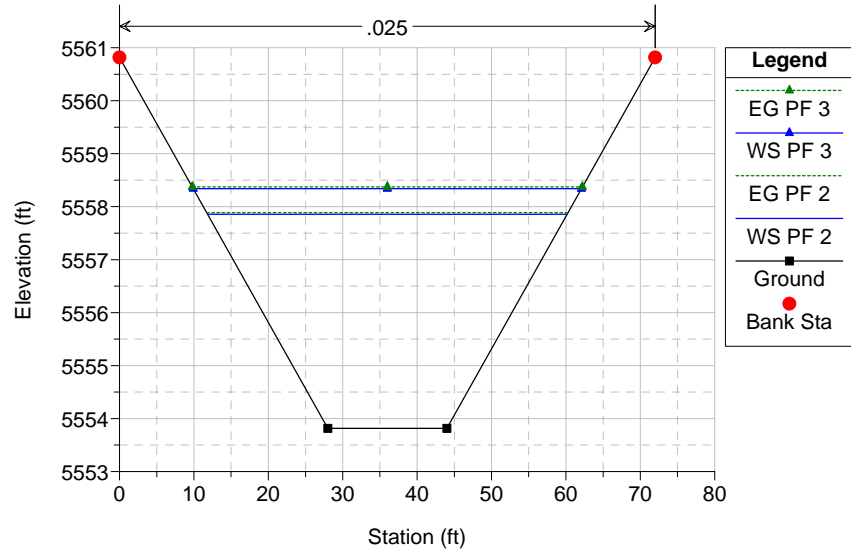
137994_RAS Plan: Option 1 - June 10 6/2/2010
RS = 11.4



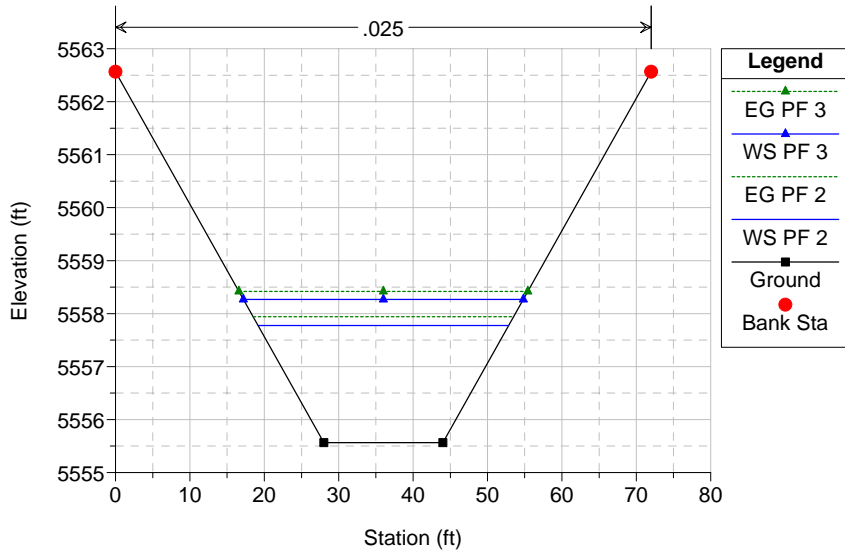
137994_RAS Plan: Option 1 - June 10 6/2/2010
RS = 12.1



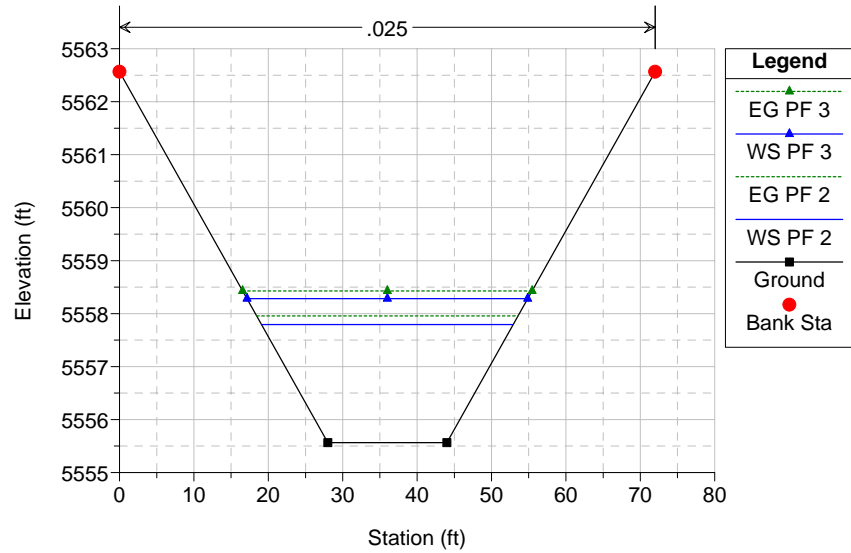
137994_RAS Plan: Option 1 - June 10 6/2/2010
RS = 12.2



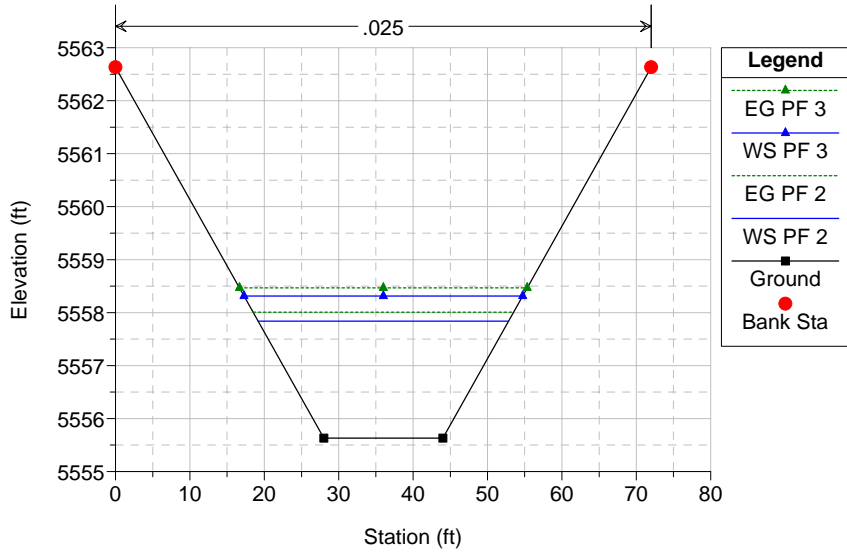
137994_RAS Plan: Option 1 - June 10 6/2/2010
RS = 12.3



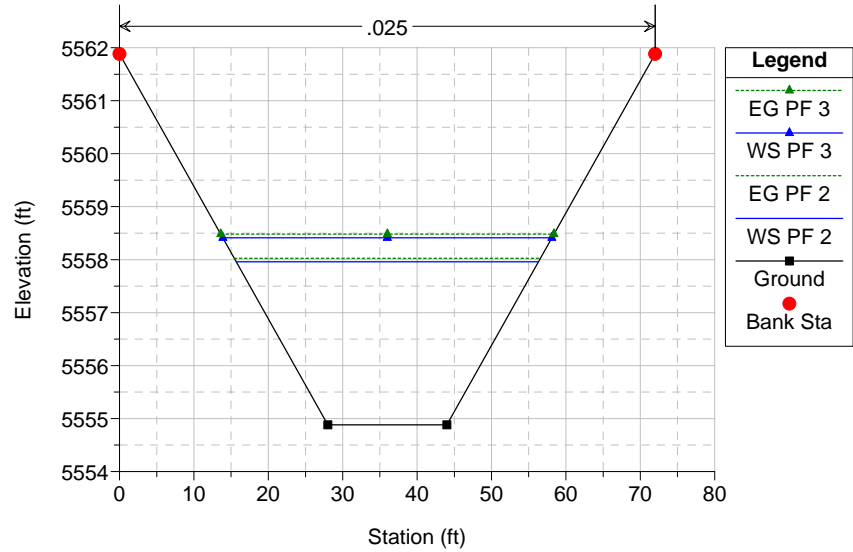
137994_RAS Plan: Option 1 - June 10 6/2/2010
RS = 12.4



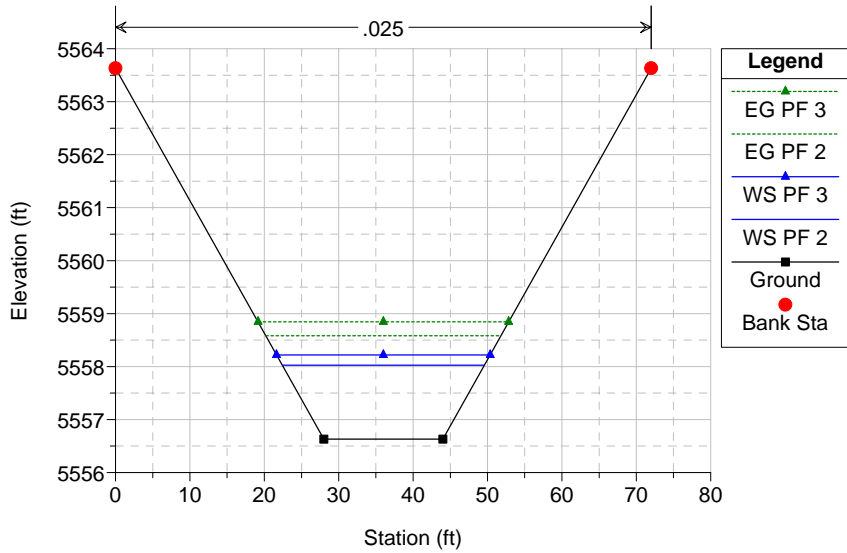
137994_RAS Plan: Option 1 - June 10 6/2/2010
RS = 13.1



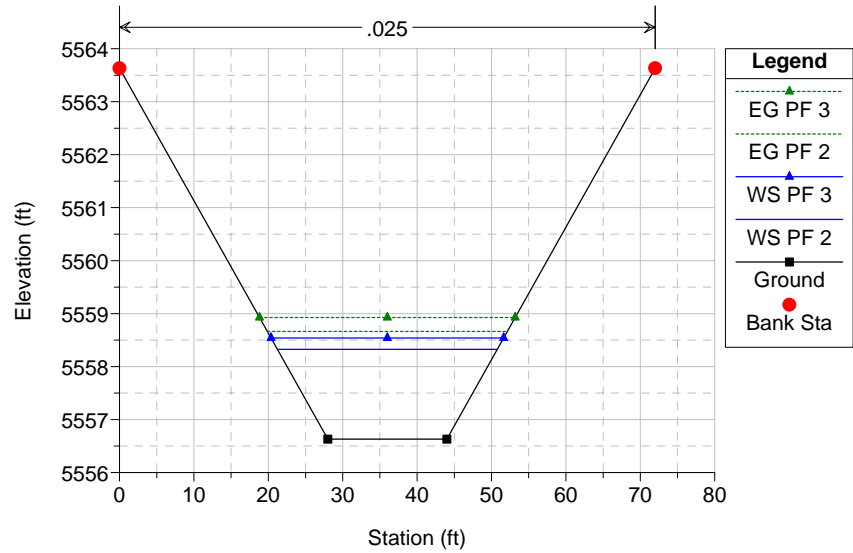
137994_RAS Plan: Option 1 - June 10 6/2/2010
RS = 13.2



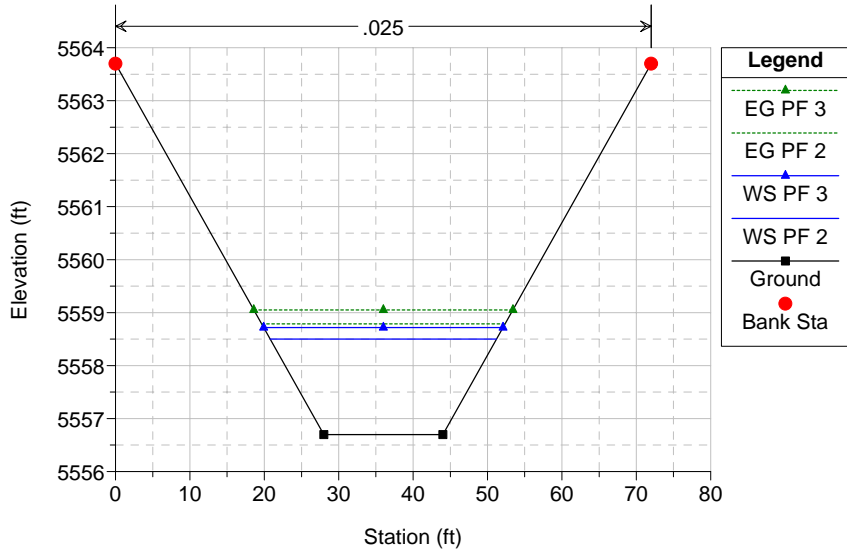
137994_RAS Plan: Option 1 - June 10 6/2/2010
RS = 13.3



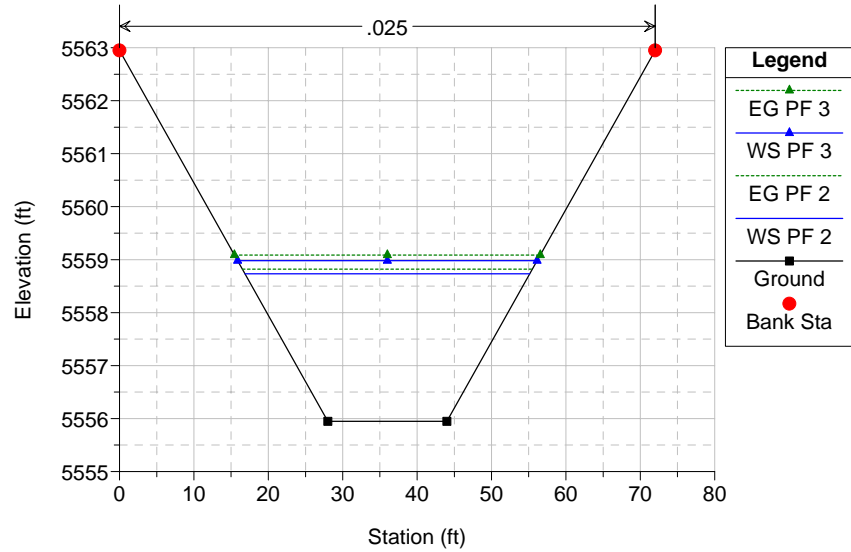
137994_RAS Plan: Option 1 - June 10 6/2/2010
RS = 13.4



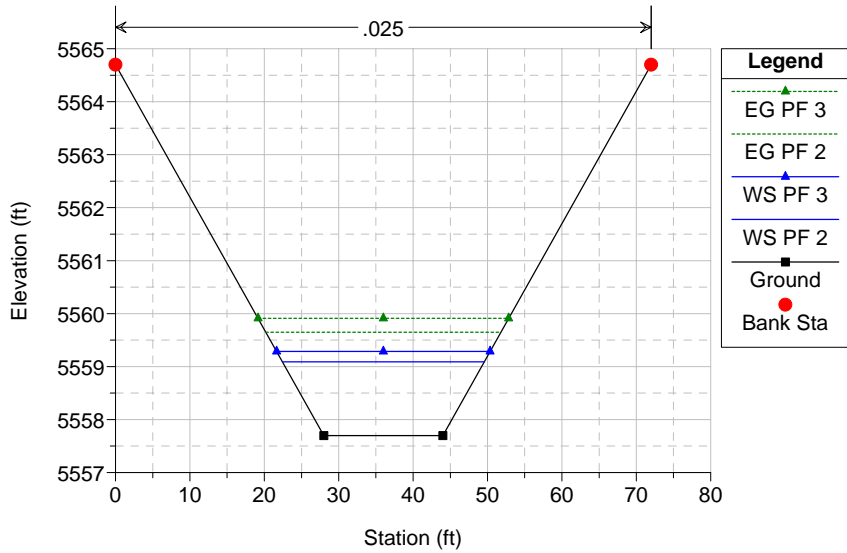
137994_RAS Plan: Option 1 - June 10 6/2/2010
RS = 14.1



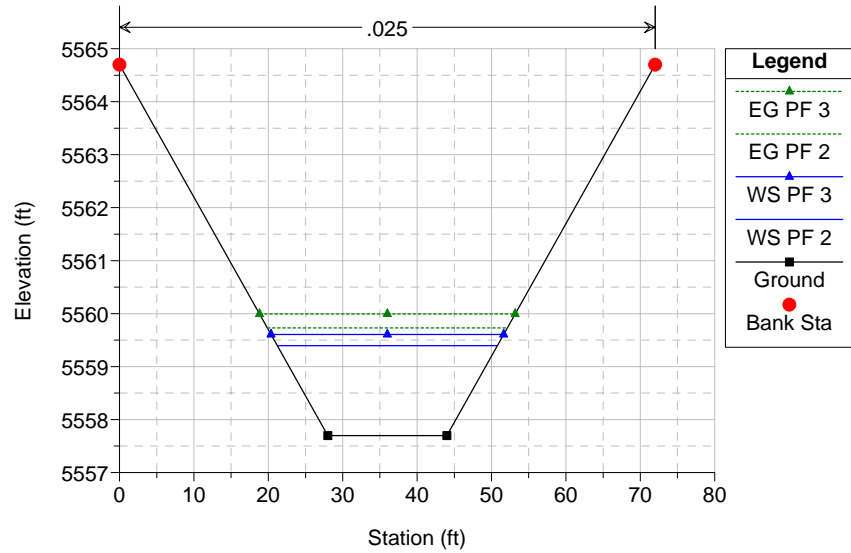
137994_RAS Plan: Option 1 - June 10 6/2/2010
RS = 14.2



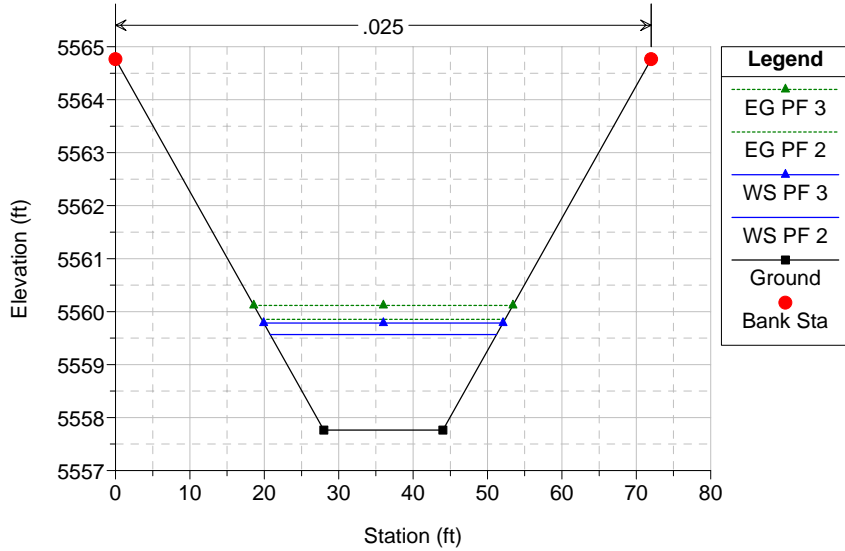
137994_RAS Plan: Option 1 - June 10 6/2/2010
RS = 14.3



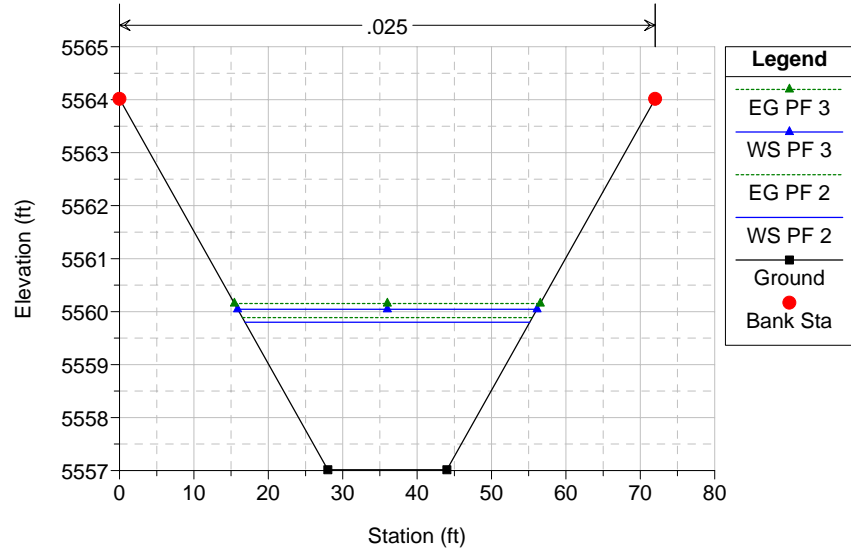
137994_RAS Plan: Option 1 - June 10 6/2/2010
RS = 14.4



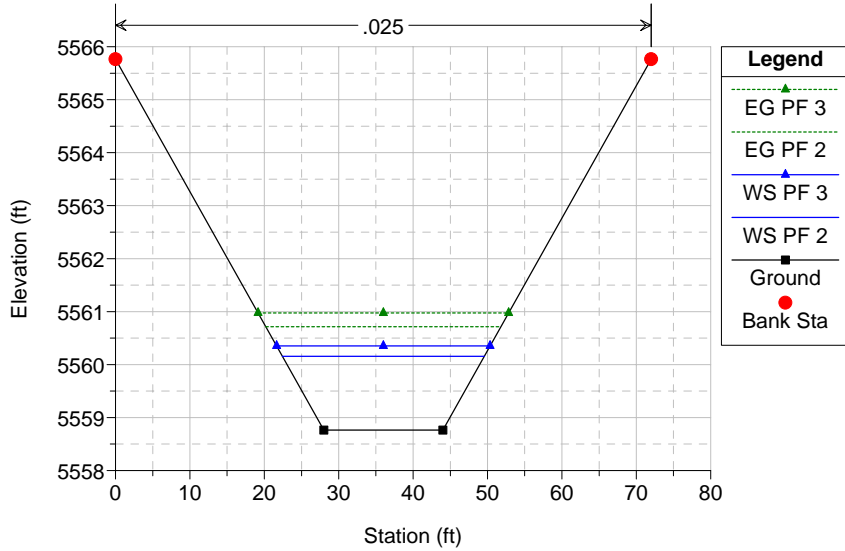
137994_RAS Plan: Option 1 - June 10 6/2/2010
RS = 15.1



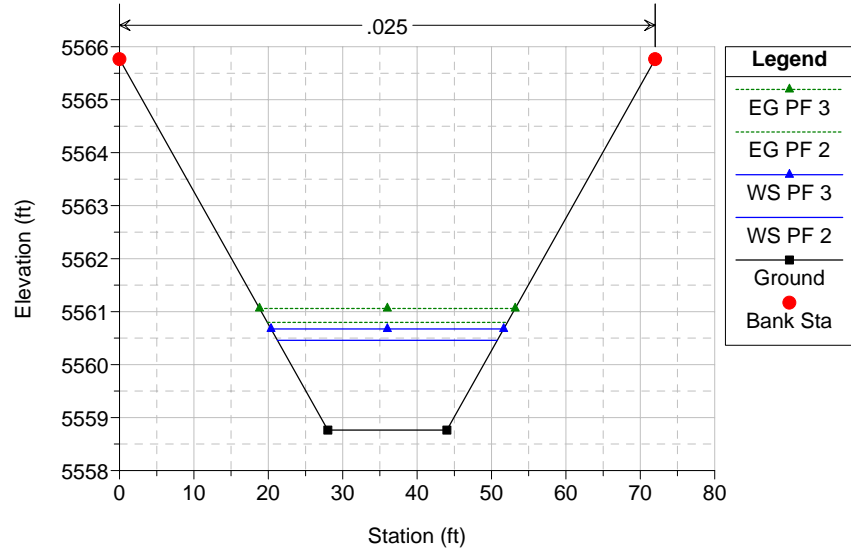
137994_RAS Plan: Option 1 - June 10 6/2/2010
RS = 15.2



137994_RAS Plan: Option 1 - June 10 6/2/2010
RS = 15.3



137994_RAS Plan: Option 1 - June 10 6/2/2010
RS = 15.4



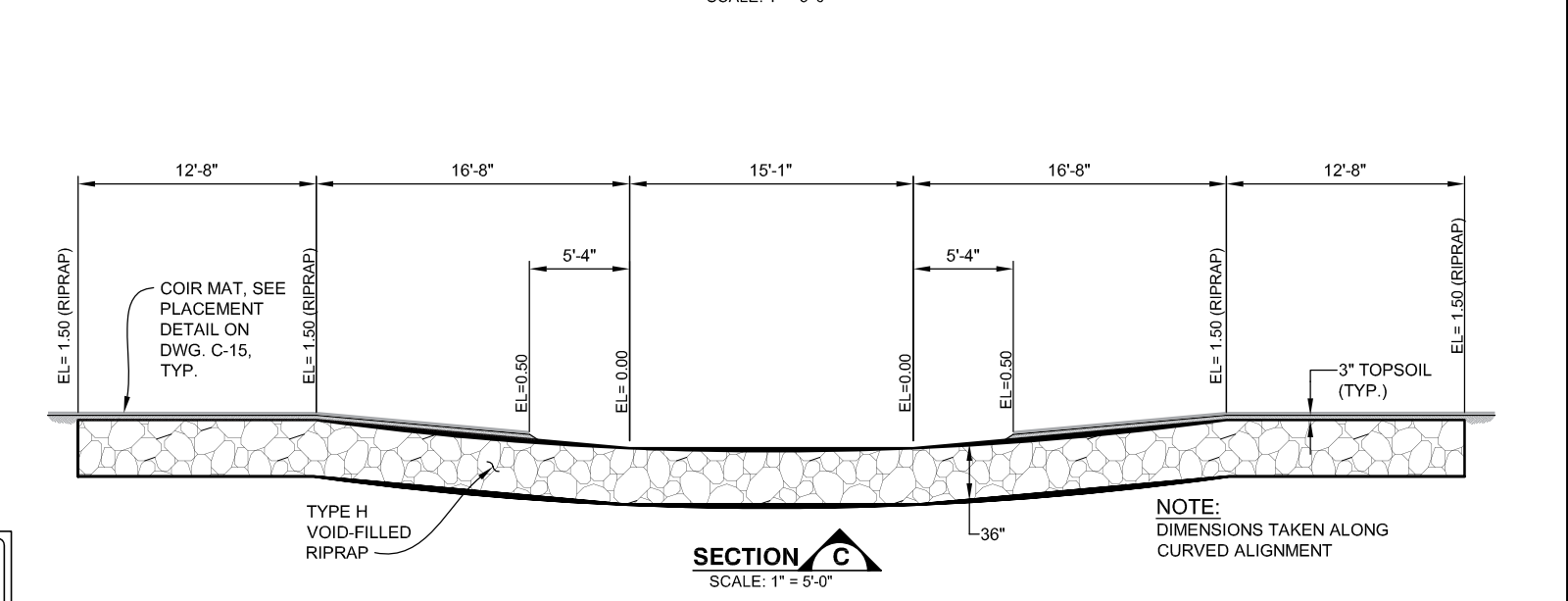
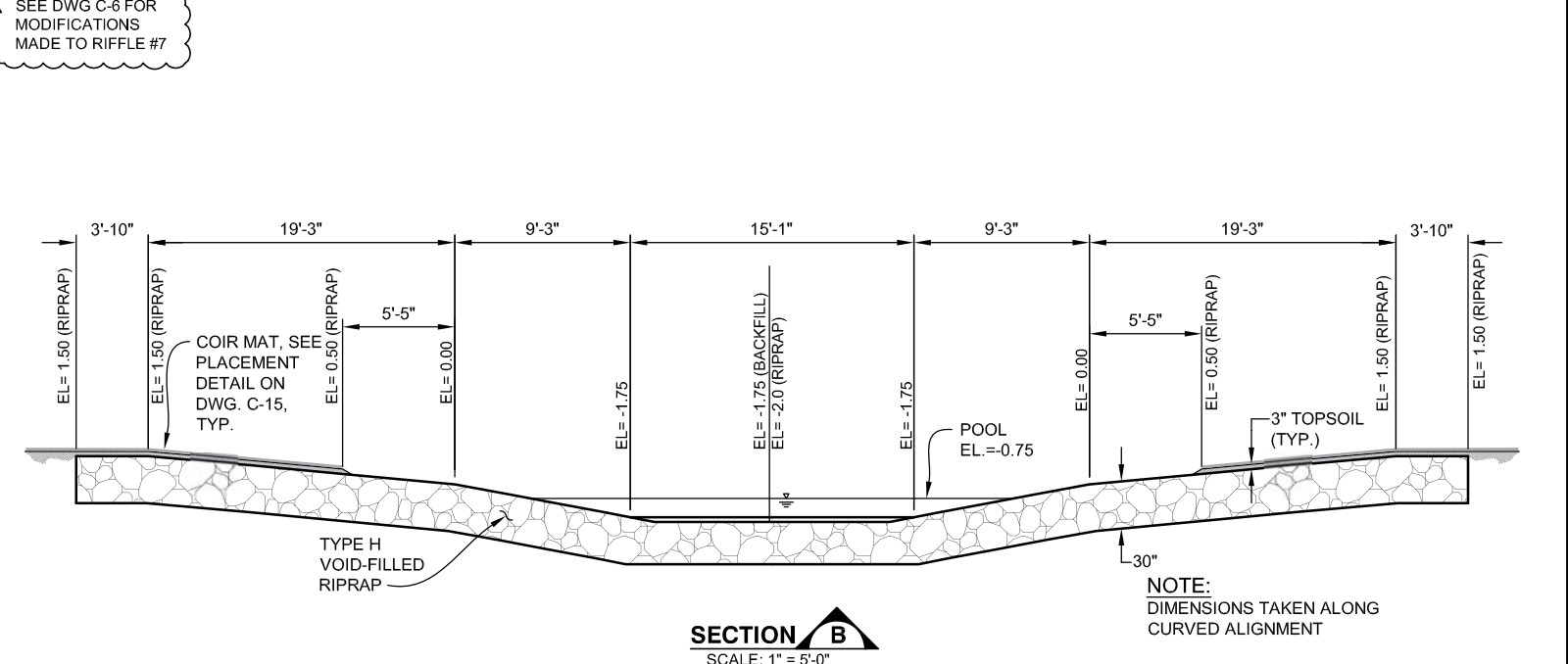
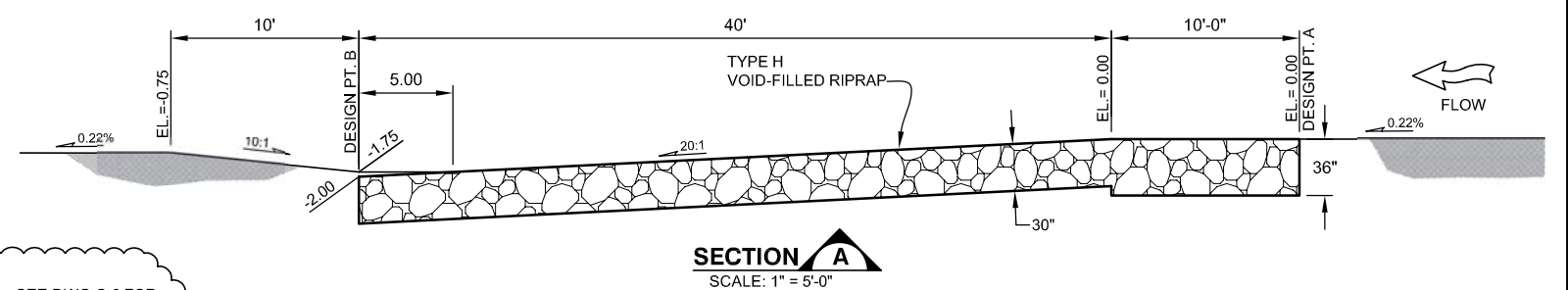
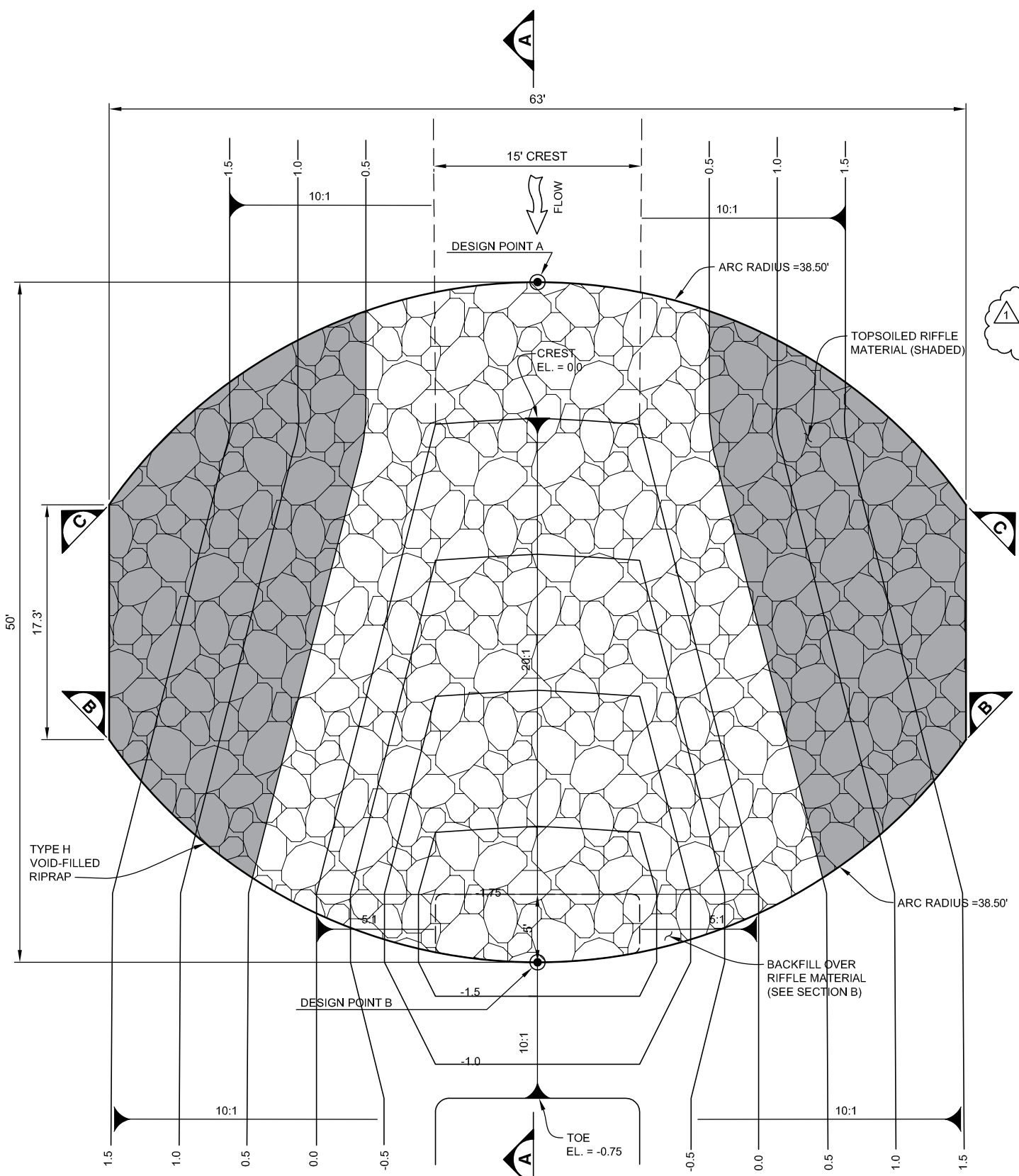
ATTACHMENT F
EARTHWORK VOLUME CALCULATION

Cherry Creek at Shop Creek Trail
Earthwork Volume Calculation

Proposed Section	Proposed Invert	Existing Section	Existing Invert	Proposed A/B Exist	Fill 1 (ft2)	Cut 1 (ft2)	Cut 2 (ft2)	(Fill 2) (ft2)	Length (ft)	Volume Fill (yd3) *	Volume Cut (yd3)	Volume Net (yd3)	
10	53.5	10	53.5	--	0.0	0.0	0.0	0.0	80	11.4	317.8	-306.4	CUT
11.1	53.5	11	54.5	B	0.0	58.5	156.0	7.0	10	0.6	70.8	-70.1	CUT
11.2	52.8	11	54.5	B	0.0	105.0	179.6	10.1	45	5.0	261.8	-256.7	CUT
11.3	54.5	11/12	53.9	A	15.6	0.0	239.5	0.0	43	26.0	445.9	-419.9	CUT
12.1	54.5	12	53.5	A	14.1	0.0	320.5	0.0	10	3.6	129.2	-125.5	CUT
12.2	53.8	12	53.4	A	3.7	0.0	377.0	0.0	45	22.0	554.1	-532.1	CUT
12.3	55.5	12	54.0	A	20.3	0.0	287.9	0.0	50	41.3	391.0	-349.8	CUT
13.1	55.6	12/13	54.9	A	20.2	0.0	134.4	0.0	10	4.1	81.7	-77.6	CUT
13.2	54.9	12/13	55.2	B	0.0	6.8	300.0	0.0	45	5.9	464.6	-458.7	CUT
13.3	56.6	13	56.3	A	6.4	0.0	264.3	0.0	38	5.0	320.0	-315.1	CUT
14.1	56.7	13	57.1	B	0.0	12.1	178.4	0.0	10	0.0	76.1	-76.1	CUT
14.2	56.0	13	57.1	B	0.0	34.2	210.2	0.0	45	38.0	325.1	-287.0	CUT
14.3	57.7	14	56.0	A	41.5	0.0	214.1	0.0	41	69.2	324.7	-255.5	CUT
15.1	57.8	14	56.1	A	41.4	0.0	213.6	0.0	10	12.1	88.9	-76.8	CUT
15.2	57.0	14	56.3	A	18.1	0.0	266.7	0.0	45	73.3	317.1	-243.8	CUT
15.3	58.8	15	56.7	A	61.9	0.0	113.8	0.0	60	75.7	126.4	-50.8	CUT
16	60.3	15	60.3	--	0.0	0.0	0.0	0.0					
TOTALS									<u>587.0</u>	<u>393.3</u>	<u>4295.2</u>	<u>-3901.9</u>	CUT

* - NOTE: Fill Volumes Increased by 10% to account for miscellaneous fill that may be required for bank stabilization outside of reach of channel where drops are to be located.

ATTACHMENT G
DROP STRUCTURE ALTERNATIVES CONSIDERED



SEE DWG C-6 FOR MODIFICATIONS MADE TO RIFFLE #7

NOTE: DIMENSIONS TAKEN ALONG CURVED ALIGNMENT

NOTE: DIMENSIONS TAKEN ALONG CURVED ALIGNMENT

- RIFFLE DROP NOTES:**
- ELEVATIONS SHOWN HERE FOR TYPICAL DROP ARE BASED ON ELEVATION 0.0 AT THE DROP CREST.
 - SEE GRADING PLAN AND PROFILE FOR ACTUAL ELEVATIONS OF DROP STRUCTURES.
 - CONTOURS SHOWN HERE WILL GOVERN GRADING IN THE IMMEDIATE VICINITY OF RIFFLE DROPS.

PLAN
SCALE: 1" = 5'-0"

RECORD DRAWING
6/27/08

THIS RECORD DRAWING HAS BEEN PREPARED, IN PART, BASED UPON INFORMATION FURNISHED BY OTHERS. WHILE THIS INFORMATION IS BELIEVED TO BE RELIABLE, MULLER ENGINEERING COMPANY, INC. CANNOT ASSURE ITS ACCURACY, AND THIS IS NOT RESPONSIBLE FOR THE ACCURACY OF THIS RECORD DRAWING OR FOR ANY ERRORS OR OMISSIONS WHICH MAY HAVE BEEN INCORPORATED INTO IT AS A RESULT. THOSE RELYING ON THIS RECORD DRAWING ARE ADVISED TO OBTAIN INDEPENDENT VERIFICATION OF ITS ACCURACY BEFORE APPLYING IT FOR ANY PURPOSE.

DATE: JUN 30, 2008 TIME: 11:29 AM

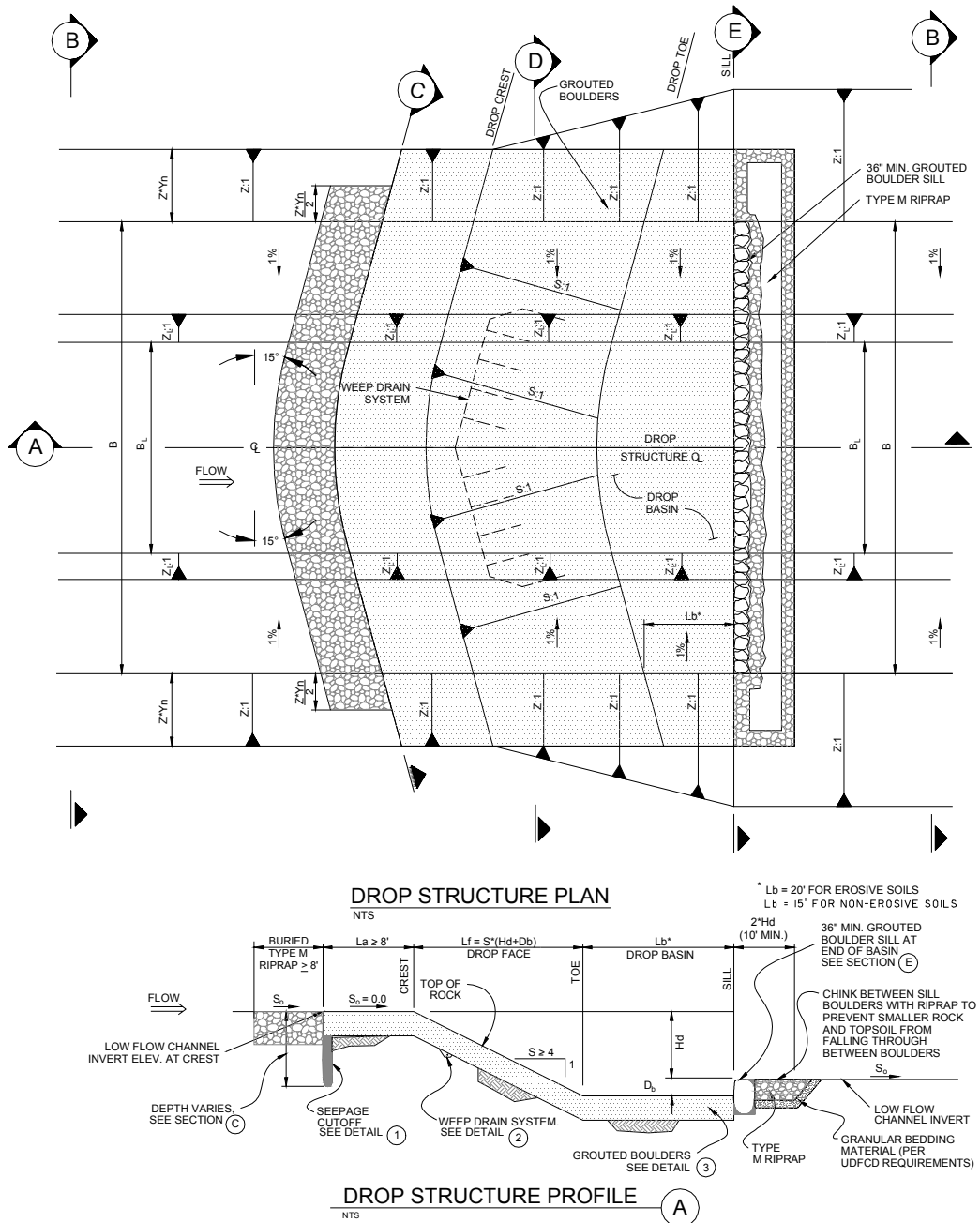
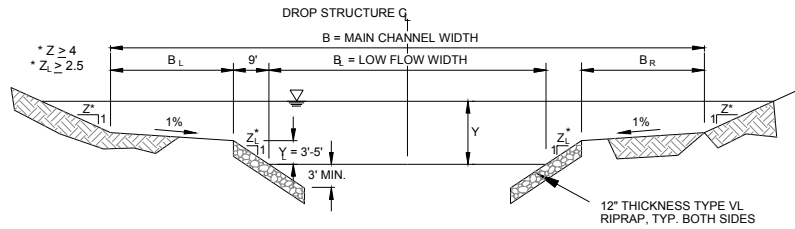
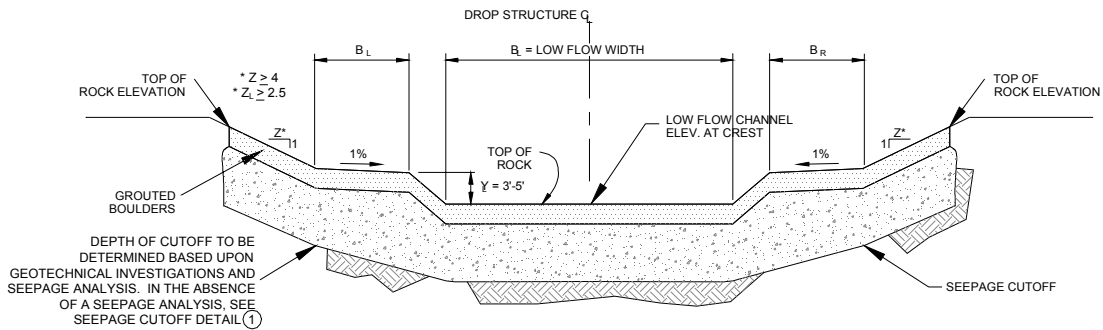


FIGURE HS-7b1

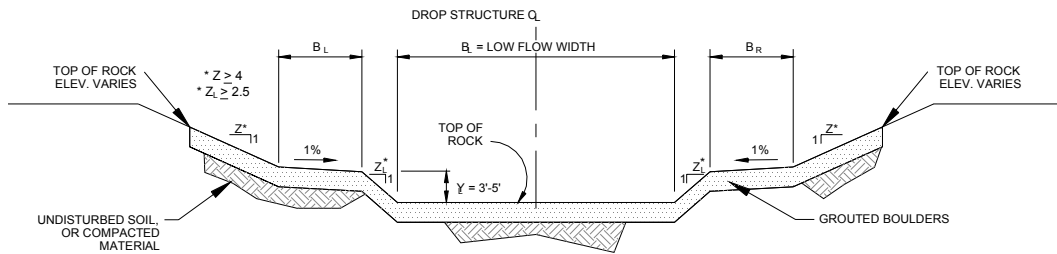
Grouted Sloping Boulder Drop With Low-Flow Channel (Figure 1 of 4)



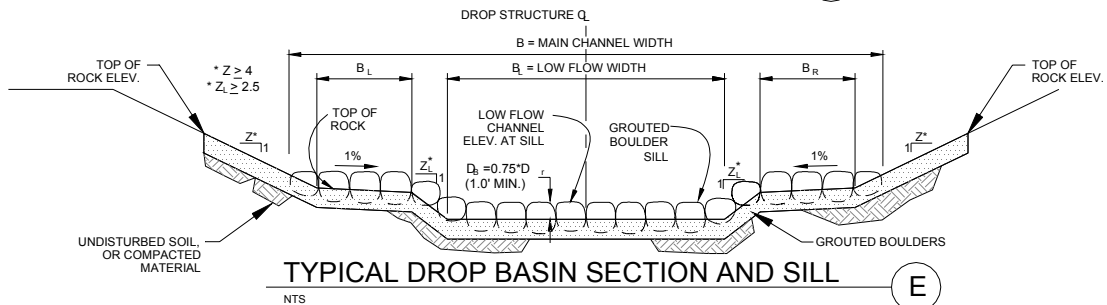
**TYPICAL CHANNEL SECTION
(UPSTREAM AND DOWNSTREAM OF DROP)** (B)



SEEPAGE CUTOFF SECTION (C)



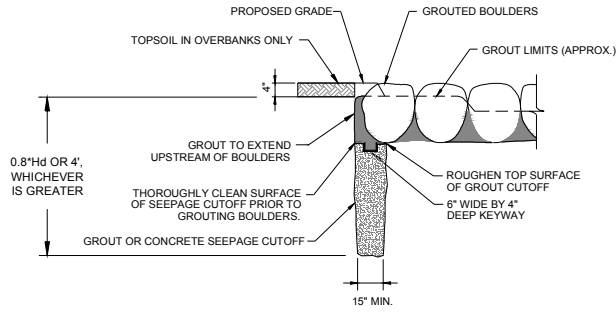
TYPICAL DROP FACE SECTION (D)



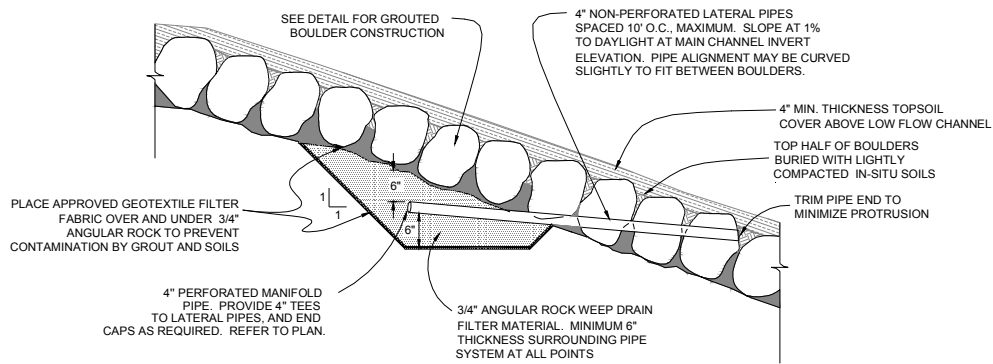
TYPICAL DROP BASIN SECTION AND SILL (E)

FIGURE HS-7b2

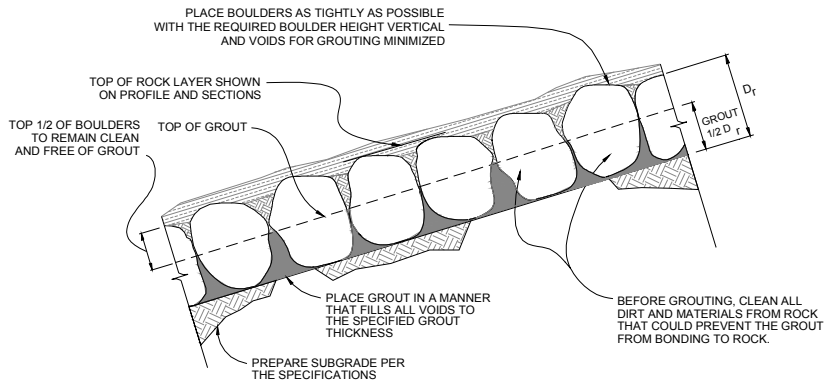
Grouted Sloping Boulder Drop With Low-Flow Channel (Figure 2 of 4)



SEEPAGE CUTOFF DETAIL 1
NTS



WEEP DRAIN SYSTEM DETAIL 2
NTS USE ONLY IN DROPS HIGHER THAN 5 FEET



GROUTED BOULDER PLACEMENT DETAIL 3
NTS

FIGURE HS-7b3

Grouted Sloping Boulder Drop With Low-Flow Channel (Figure 3 of 4)